



Wrecker and Tow Car Operator Guide



March 2012

PREFACE

The Nevada Department of Motor Vehicles has prepared this guide to assist Nevada Automobile Wreckers and Tow Car Operators when conducting business with the Department. It was created as an informational and instructional reference, and attention to the detailed information and examples will ensure proper completion of forms required to register and/or title vehicles in the State of Nevada.

Implementation of requirements as outlined in this guide and attention to detail when completing forms will be beneficial to you, your customers and the Department. Documents properly prepared and submitted will ensure that our records are correct. This allows the Department to respond to inquiries from consumers, vehicle industry members and law enforcement with up to date, accurate information.

If you have any suggestions that may help improve this guide, please provide them in writing to:

Nevada Department of Motor Vehicles
Management Services and Programs Division
Vehicle Programs
555 Wright Way
Carson City, NV 89711

<p>The March 2012 revision includes updated information from the 2011 Legislative Session Assembly Bill 204 and Senate Bill 150.</p>
--

Table of Contents

Section I – General Information	I-1
Guidelines	I-2
Importance of Accuracy	I-2
Vehicle Identification Number (VIN) Information	I-3
VIN Schematic / Description	I-3
Incomplete or Incorrect Documents.....	I-4
Notary Public	I-4
Wrecker and Salvage Pool Licensing Information	I-5
Definitions	I-5
Licensing Requirements	I-6
Additional Licensing Privileges	I-7
Acquiring Vehicles	I-7
Partial Vehicles	I-8
Determining a Vehicle is Whole or Partial	I-8
Motor Home Descriptions	I-8
Section II – Ownership Documents	II-1
Nevada Certificate of Title.....	II-2
Front of Title Field Descriptions	II-3
Front of Title Sample	II-5
Back of Title Field Descriptions	II-7
Back of Title Sample.....	II-8
Nevada Salvage Title.....	II-10
Front of Title Sample	II-11
Back of Title Sample.....	II-13
Out of State Salvage Certificates.....	II-15
Retention of Salvage Vehicles	II-15
Non-Repairable Vehicle Certificate.....	II-16
Front of Certificate Sample.....	II-17
Back of Certificate Sample	II-19
Junk Certificate/Appraisal	II-20
Front of Certificate Sample.....	II-21
Back of Certificate Field Descriptions and Sample	II-23
Section III – Forms	III-1
Application for Salvage Title or Non-Repairable Vehicle Certificate.....	III-2
Authorization for Vehicle Restoration.....	III-5
Bill of Sale.....	III-7
Certificate of Inspection / Affidavit Vehicle Construction	III-9
Instruction for Completing VP-64.....	III-11
Instruction for Completing VP-64M.....	III-15
Instruction for Completing VP-223.....	III-19
Certificate of Inspection for Rebuilt Vehicles.....	III-22
Erasure Affidavit.....	III-26

Lien Release / Satisfaction of Lien.....	III-28
Power of Attorney	III-30
Vehicle Inspection Certificate.....	III-33
Section IV – Fees	IV-1
Title Fees	IV-2
Section V – Abandoned Vehicles and Lien Sales	V-1
Lien Sales	V-2
Notice of Lien Sale.....	V-2
Towing Abandoned Vehicles	V-5
Abandoned Vehicle Lien Sale Transfer.....	V-6
Authority to Recover Claim not paid by Sale.....	V-6
Validity may be Contested	V-6
Private Property Abandoned Vehicle Release	V-7
Notification Abandoned Vehicle Liens.....	V-9
Requirements for the Tow Bill	V-10
Vehicles Abandoned at a Salvage Yard.....	V-11
Letter of Transmittal for Abandoned Junk Vehicles.....	V-12
Appraisal Report for Abandoned Vehicles	V-14
Vehicles Valued Under \$500	V-14
Vehicles Valued Over \$500	V-16
Demand for Payment.....	V-17
Verified Mailing	V-18
Advertisement of Sale.....	V-19
Affidavit of Publication.....	V-20
Sale by Public Action	V-21
Submitting Lien Sale Documents.....	V-21
Collecting Sales Tax	V-21
Lien Sale Affidavit	V-22
Lien Sale Registration Certification.....	V-27
Request for Extension of Time for Submitting Lien Sale Documents.....	V-29
Section VI – Records Section.....	VI-1
Accessing Department of Motor Vehicle Information	VI-2
Vehicle Registration, Title, and History Information	VI-3
Application for Records Service	VI-4
Affidavit for Individual Record Information	VI-5
Records Section Fee Schedule	VI-6
Section VII – Glossary and Index	VII-1
Glossary.....	VII-2
Index.....	VII-11

Section I

General Information

Guidelines

Always type or print in black or dark blue ink.

The owner's full legal name and address information must be recorded on registration and title documents exactly as it reads on the owner's driver's license.

Ensure the Vehicle Identification Number (VIN), year, make, odometer readings and registered owner and legal owner information are consistent on all documents.

Signatures must always be handwritten, unless waived by the Department because the submittal is done by electronic means. A printed release will not be accepted unless accompanied by a notarized or witnessed statement (from the person in question) stating that the signature is a legal signature.

Do not use correction fluid or correction tape.

Do not alter any information on documents.

A release should be the same, as it appears on title documents, i.e., Elizabeth should sign as Elizabeth.

All documents must be originals, unless certified to be true copies of the original document. Only certain documents can be accepted as true and exact copies.

Importance of Accuracy

The Department of Motor Vehicles uses the VIN as the primary identifier for entry and retrieval of records. It is therefore critical that all documents are completed using the correct VIN.

TO AVOID ERRORS:

- Ensure the entire VIN is used at all times.
- Ensure the VIN is entered or recorded legibly and accurately. It is best to use block letters.
- If the VIN is handwritten, try to avoid the following most common errors:

<u>LETTER</u>	<u>MAY BE MISTAKEN FOR</u>
B	13 or 8
D	0
G	6 or C
J	T or I or 5
R	K
S	5

Y	4 or H
U	Y or V
Z	2 or a 7 on a line

“l” and “1” are often confused. The letter “l” is rarely used in a VIN. The number 9 and/or 4 can also be confused if not written legibly.

The letter “O” is never used in a VIN, with the exception of state assigned VINs, such as those that are assigned by the states of Colorado (i.e., COLO123456) or Missouri (DR000000MO or DRMVB0000000000MO).

Vehicle Identification Number (VIN) Information

Since 1954, American automobile manufacturers have used a Vehicle Identification Number (VIN) to identify and describe a vehicle.

Since 1981, all manufacturers of vehicles sold in the United States are required to use a standardized 17-digit VIN structure. When the Department is provided with a vehicle that has an 18-digit VIN, the VIN will be verified before the vehicle information is entered.

Variations exist in the location of a VIN and in the systems used for a VIN; they may vary by year of manufacture and between manufacturers.

A VIN should always be verified by a physical inspection of the vehicle.

VIN Schematic / Description

Position	Description
1-3	Manufacturer Identifier
4	Restraint System Type
5	Manufacturer Specification
6	Line, Series, Body Type
7-8	Engine Type
9	Check Digit
10	Model Year
11	Assembly Plant
12-17	Production Sequence Number

1st Character: Identifies the country in which the vehicle was manufactured, i.e., USA (1 or 4), Canada (2), Mexico (3), Japan (J), Korea (K), England (S), Germany (W), Italy (Z).

2nd Character: Identifies the manufacturer, i.e., Audi (A), BMW (B), Buick (4), Cadillac (6), Chevrolet (1), Chrysler (C), Dodge (B), Ford

- (F), GM Canada (7), General Motors (G), Honda (H), Jaguar (A), Lincoln (L), Mercedes Benz (D), Mercury (M), Nissan (N), Oldsmobile (3), Pontiac (2 or 5), Plymouth (P), Saturn (8), Toyota (T), VW (V), Volvo (V).
- 3rd Character: Identifies the vehicle type or manufacturing division.
- 4th to 8th Characters: Identifies vehicle features such as body style, engine type, model, series, etc.
- 9th Character: Identifies the VIN accuracy as a check digit.
- 10th Character: Identifies the model year, i.e., 1988 (J), 1989 (K), 1990 (L), 1991 (M), 1992 (N), 1993 (P), 1994 (R), 1995 (S), 1996 (T), 1997 (V), 1998 (W), 1999 (X), 2000 (Y), 2001 (1), 2002 (2), 2003 (3), 2004 (4), 2005 (5), 2006 (6), 2007 (7), 2008 (8), 2009 (9), 2010 (A), 2011 (B), 2012 (C), 2013 (D), 2014 (E), 2015 (F). 2016 – 2029 use G thru X – 2030 (Y), and 2031-2039 use digits 1 thru 9.
- 11th Character: Identifies the assembly plant for the vehicle.
- 12th to 17th Characters: Identifies the sequence of the vehicle for production as it rolled off of the manufacturer's assembly line.

If a manufacturer produces less than 500 vehicles per year, the VIN characters along with the third, fourth and fifth characters of the fourth section shall uniquely identify the manufacturer, make and type of motor vehicle. (Title 49 CFR, Section 565.6 Content Requirements)

Incomplete or Incorrect Documents

For questions concerning incomplete or incorrect documents please contact the Department of Motor Vehicles, Title Section.

Department of Motor Vehicles
Central Services and Records Division
Attn: Title Section
555 Wright Way
Carson City, NV 89711-0700
(775) 684-4810

Notary Public

A Nevada licensed dealer's signature is not required to be acknowledged by a notary public on documents that the dealer must file with the Department, except in regard to deposit in lieu of bond. Nevada Revised Statutes (NRS) 482.3275

If a document must be notarized, the provisions of NRS 240.010 through 240.150 must be followed.

A notary public may not perform any act authorized by NRS 240.065 if he or she:

1. Executed or is named in the instrument acknowledged or sworn to;
2. Will receive directly from a transaction relating to the instrument any commission, fee, advantage, right, title or interest, property or other consideration in excess of the authorized fees; or
3. Is related to the person whose signature is to be acknowledged or sworn to as a spouse, sibling, or lineal ancestor or descendant.

Wrecker and Salvage Pool Licensing Information

Definitions

“Wrecker” defined. “Automobile Wrecker” means a person licensed by the Department who dismantles, scraps, processes or wrecks a vehicle subject to the registration laws of Nevada. NAC 487.010.

“Salvage Pool” defined. “Salvage Pool” means a business which obtains motor vehicles from:

1. Insurers and self-insurers for sale on consignment or as an agent for the insurer or self-insurer if the vehicles are acquired by the insurer or self-insurer as the result of a settlement for insurance; or
2. Licensed vehicle dealers, rebuilders, lessors or wreckers for sale on consignment. NRS 487.400.2

Wrecker and Salvage Pool require separate business licenses and fees.

Licensing Requirements

1. Application for Business License (OBL237) completed in full and signed by a principal of the business.
2. Personal History Questionnaire (DS242) completed by each principal or corporate officer being listed on the license application.
3. Authorization for Release of Information (DS254) signed by each principal or corporate officer. Release must be notarized or signature witnessed by an authorized DMV representative.
4. Child Support Information (DS268) completed and signed by each principal.
5. Licensee Acknowledgement form (DS308).
6. A surety bond (DS262) or deposit in lieu of bond in the amount of \$50,000.
7. If applying for wrecker or salvage pool plates an insurance certificate showing automobile liability coverage. See insurance information sheet (OBL273).
8. Non-refundable license application fee of \$300.

9. City or County business license.
10. Fictitious Firm Name Filing.
11. Copy of Certificate of Incorporation and Corporate filing, with names of the officers, filed with the State of Nevada, Secretary of State's Office, if applicable.
12. The federal identification number of the business.
13. An electronic mail address for the business.
14. An established place of business, with a permanently enclosed building located on at least one-half acre. The business location must be surrounded by a screened fence at least six feet tall.
15. A permanently affixed display sign with the name of the business in lettering eight inches high, formed by lines that are at least one inch wide. Sign must be clearly legible from the center of the nearest street or roadway.
16. Two color photographs that clearly show the exterior of the business to include the display sign.

It is unlawful for any person to dismantle, scrap, process or wreck any vehicle without first applying for and obtaining a license for that operation from the Department. NRS 487.050.1.

No person may operate a salvage pool without first applying for and obtaining a license for that business from the Department. NRS 487.410.1.

Additional Licensing Privileges

Wreckers Only - I.D. cards may be obtained, which authorizes a licensed wrecker to bid to purchase a vehicle from an operator of a salvage pool. A licensed wrecker may obtain two cards annually for his business at a fee of \$50 each card. I.D. cards expire April 30th of each year for which it was issued. NRS 487.070(2)(3).

Electronic Submission of a Non-Repairable Vehicle Certificate – NRS 487.470

Licensed Nevada Wreckers may participate in a program where they may submit electronically a notification that they have acquired a vehicle and will process the vehicle as parts or scrap metal. The Department will issue a Non-Repairable Vehicle Certificate with the Wrecker listed as the Owner.

The wrecker must complete and submit an updated Application for Business License and Garage Registration form OBL237 and a separate Vehicle Industry Business License Bond form OBL262 in the amount of \$50,000 for this additional activity with the Compliance Enforcement Division, Occupational and Business Licensing (OBL). Once the activity has been approved, the wrecker must also complete a Terms of Participation OBL323 and an External DMV User Information Technology Security Form for the issuance of an ID and password in order to access the DMV's transaction to submit the records. The wreckers will contact OBL for helpdesk assistance, if needed.

When an approved Wrecker uses this program, the vehicle's title work does not have to be sent to the DMV. If a wrecker is not an approved Wrecker then he must use the Application for Salvage Title or Non-Repairable Vehicle Certificate form VP213 and submit the title documents to apply for a Non-Repairable Vehicle Certificate.

Out of state vehicles can be processed. When the vehicle is entered, the DMV will check the vehicle to see if it is stolen. The wrecker must report stolen vehicles to their local law enforcement agency and cannot process the vehicle for parts or scrap metal.

For more information on this process please contact your local Occupational and Business Licensing office.

Acquiring Vehicles

Nevada automobile wreckers may acquire vehicles in the following manner:

1. By direct purchase, with the owner providing title documents.
2. By direct purchase, with an automobile wrecker providing a salvage title, non-repairable vehicle certificate or junk certificate.
3. By direct purchase, with an insurance company or its agent providing a salvage title, non-repairable vehicle certificate.
4. By direct purchase, with a salvage pool providing salvage title, non-repairable vehicle certificate or junk certificate. The salvage pool must also be a licensed wrecker or tow operator to obtain a junk certificate.
5. Through receipt of a vehicle removed from public or private property at the request of an enforcement agency, owner, or person in lawful possession of the property. The lien sale process must follow pursuant to NRS 108.265 through 108.367 inclusive.
6. Lien Process.
7. Junk Certificate: Issued to a licensed wrecker or tow operator.

Partial Vehicles

When an automobile wrecker acquires parts of a vehicle through purchase or exchange, a bill of sale from the owner of the parts must be maintained.

1. If a vehicle that has been partially dismantled is acquired, a written statement from the owner, listing those parts that have previously been removed is required.
2. If the part includes the frame or other major component, a salvage title may be required.

Determining a Vehicle is Whole or Partial

1. Whenever an entire salvage vehicle is sold to any person by a licensed automobile wrecker, the automobile wrecker shall deliver a properly endorsed salvage title to the buyer for such an entire salvage vehicle.
2. A salvage vehicle shall be deemed an entire salvage vehicle:
 - (a) If all the following essential components are included and identifiable as coming from the same salvage vehicle:
 - (1) The cowl assembly;
 - (2) The floor pan assembly;
 - (3) The passenger compartment;
 - (4) The rear clip assembly; and
 - (5) The roof assembly; and
 - (b) In addition to the essential components required pursuant to paragraph (a):
 - (1) If the salvage vehicle was manufactured with a conventional frame, the conventional frame is included and identifiable as coming from the same salvage vehicle;
 - (2) If the salvage vehicle was manufactured with a unibody, the complete front inner structure is included and identifiable as coming from the same salvage vehicle;
 - (3) If the salvage vehicle is a truck which was manufactured with a conventional frame, the conventional frame and the truck cab assembly are included and identifiable as coming from the same salvage vehicle; and
 - (4) If the salvage vehicle is a truck which was manufactured with a unibody, the complete front inner structure and the truck cab assembly are included and identifiable as coming from the same salvage vehicle.
3. A salvage vehicle that does not satisfy the requirements of subsection 2 is deemed a part or parts of an entire salvage vehicle.

Motor Home Descriptions

Motor homes are vehicles described as permanently attached to a self-propelled chassis and are designed for use as temporary living quarters. Nevada Revised Statutes defines three types of motor homes.

Note: The legal maximum width of a recreational vehicle is 102 inches excluding mirrors, lights and other devices required for safety; and an awning and any hardware used to attach the awning, but it cannot extend beyond any mirror.

Mini motor home (NRS 482.066): A vehicular-type unit designed for temporary living quarters for travel, camping or recreational use, which is:

1. A structure attached permanently on a self-propelled chassis; or
2. A portable unit designed to be affixed permanently to a truck chassis with cab, which is designated as a mini motor home by the manufacturer.

Motor home (NRS 482.071): A structure:

1. Attached permanently to a self-propelled motor vehicle chassis;
2. Designed as a temporary dwelling for travel, recreational or camping use; and
3. When assembled for the road, having a maximum body width of 102 inches.

Chassis-mount camper (NRS 482.0151):

A portable unit designed to be permanently affixed to a truck chassis and cab, and so constructed as to provide temporary living quarters for travel, camping or recreational use.

In all cases, the chassis/frame number is used as the Vehicle Identification Number (VIN). The make of the vehicle is the motor home name, not the chassis/frame manufacturer.

Example: Winnebago makes the Itasca and Fleetwood makes the Tioga. The makes are therefore Itasca and Tioga; Winnebago and Fleetwood are not used.

The vehicle year is established by the manufacturer on the vehicle's original documentation.

In all cases, the vehicle length must be included on the registration and title documents as part of the vehicle description.

Recreational park trailer (NRS 482.1005) means a vehicle, which is primarily designed to provide temporary living quarters for recreational, camping, or seasonal use and which:

1. Is built on a single chassis mounted on wheels;
2. Has a gross trailer area not exceeding 400 square feet in the set-up mode; and
3. Is certified by the manufacturer as complying with Standard No. A119.5 of the American National Standards Institute.

Note: The Department will issue a title only for recreational park trailers because they are over 102 inches in width. Moving a recreational park trailer requires a special movement permit issued by the Department of Transportation.

Section II

Ownership Documents

NEVADA TITLE

NRS 482.245, 482.260, 482.285 and 482.400

There are currently several valid styles of Nevada Certificates of Title (Form VP-2, VP2S, and VP2NR) in circulation. For the purpose of this guide, only the two most recent styles will be displayed (Revisions 8/10 and 1/06). The older versions of the Nevada Titles are online at www.dmvnv.com/title.htm.

The registered owner or seller must sign the certificate of title exactly as the name appears on the face of the certificate of title.

- If there is more than one registered owner or seller, and they are joined by “and,” the signature of each owner or seller is required.
- If there is more than one registered owner or seller, and they are joined by “and/or” or “or,” only one of the owner’s or seller’s signature is required.
- If there is more than one registered owner or seller, and not joined by “and” or “and/or” or “or,” the signature of each registered owner or seller is required. The Department considers no name indicator as “and” in these cases.
- If the registered owner or seller information is in the name of a business, the name of the business must appear along with the signature of an authorized business representative.

Buyer information must be completed indicating exactly how the new Certificate of Title is to read, using the buyer’s full legal name as it appears on their driver’s license. When the buyer is a business, use their FEIN and the full business name.

NEVADA CERTIFICATE OF TITLE
(FORM VP-2)

1. Vehicle Information: The vehicle identification number, year, make, model and vehicle body.
2. Title Number: The number assigned at the time the title is created.
3. Date Issued: The date the title was issued.
4. Odometer Miles: The reading indicated on the vehicle's odometer apparatus.
5. Fuel Type: The type of fuel the vehicle uses.
6. Sales Tax Paid: Nevada does not print this information at this time.
7. Empty Weight: The actual weight of the vehicle when empty.
8. Gross Weight: The maximum recommended weight of the vehicle when full (passengers, luggage, etc.).
9. GVWR: The gross vehicle weight rating (the weight of the vehicle plus the vehicle's useful or maximum-load).
10. Vehicle Color: The color of the vehicle. Nevada does not capture the vehicle color at this time.
11. Odometer Brand: The actual status of the odometer reading.
 - A. Actual Mileage; the miles shown on the odometer are the exact miles the vehicle has been driven, required for all vehicles that are nine years and newer and do not meet exemptions in Title 49 Odometer Disclosure.
 - B. Exceeds Mechanical Limits; the vehicle has traveled more miles than the odometer is capable of showing.
 - C. Warning Odometer Discrepancy; the odometer reading is not the actual mileage (the odometer may have been broken or a new odometer may have been installed).
 - D. Exempt; the vehicle is ten years old or older or meets the exemption qualifications in Title 49 Odometer Disclosure.
12. Brands: The description of a vehicle that applies. When more than one brand applies, those brands will be listed:
 - Flood Damage
 - Lemon Law Buyback
 - Non-Rebuildable
 - Non-U.S. Vehicle
 - Not Street Legal
 - Rebuilt
 - Total Loss
 - Reconstructed
 - Specially Constructed
13. Owner(s) Name and Address: The name and address of the person or persons the Certificate of Title is issued to.
14. Lienholder(s) Name and Address: The name and address of the legal owner of the vehicle who holds the security interest if different from number 13.
15. Lienholder(s) Release: All Nevada Certificates of Title that show a lienholder require a release of lien to transfer ownership. The lienholder or authorized agent of the lienholder must complete this section. The signature of the lienholder or the authorized agent and the date of the signature are required to complete the release.

If the lienholder is a business, the business name must appear along with the signature of an authorized representative of the business.

16. Full Legal Name and Address of Buyer(s): Record the registered owner's full legal name exactly as it appears on the customer's driver's license, identification card, or business license. This is the name that will be recorded on the vehicle registration certificate and Certificate of Title when created. Customers purchasing a vehicle(s) for a business are not required to present their business license.

Note:

- If the registration is to read "doing business as" enter "DBA" preceding the business name.
- If the vehicle is leased, the words "Lessee" and "Lessor" must be included prior to the full legal name
- If there is more than one Lessee, separate the Lessees with a semi-colon ";".

17. Nevada Driver's License, Identification Card Number, or FEIN for businesses: Enter the number based on the document presented during the purchase transaction. The DMV will use these numbers to ensure the full legal name of the owner is placed on the registration and title.

Note:

- If the customer does not have a Nevada driver's license or identification card, "No Nevada DL or ID" must be printed in the registered owner's information area.
- Customers purchasing a vehicle(s) for a business that does not have a FEIN (Federal Employer Identification Number), enter "No FEIN."
- Do not enter or use the customer's social security number.

18. And/Or: If the registration and title are in more than one name, the appropriate box must be marked to indicate "and" or "or." Using "and" will require all persons on the title to sign the title to release interest in the vehicle. "Or" will allow for one person to sign the title to release interest in the vehicle, if there are two or more recorded owners.

19. Odometer Reading: The odometer reading must be recorded exactly as it shows on the vehicle's odometer apparatus, excluding tenths. The seller(s) must complete the Odometer Statement to the best of their knowledge.

20. Odometer Declaration: If the odometer reading is not the actual mileage of the vehicle, one of the statements must be checked. The Certificate of Title will be branded accordingly.

21. Signature and Printed Name of the Seller(s)/Agent/Dealership.

22. DMV issued Dealer's License Number.

23. Date of Sale: The actual date ownership of the vehicle was transferred.

24. Signature and Printed Full Legal Name of the Buyer(s).

Note: Any alteration or erasure voids a Nevada Certificate of Title. The control number in the lower right hand corner of the Certificate of Title is not the title number. The Department uses this number internally.

Front of Title
Revised 8/2010

STATE OF NEVADA
DEPARTMENT OF MOTOR VEHICLES

CERTIFICATE OF TITLE

VIN **1** **1** YEAR **1** MAKE **1** MODEL **1** VEHICLE BODY **2** TITLE NUMBER

DATE ISSUED **3** **4** ODOMETER MILES **5** FUEL TYPE **6** SALES TAX PD **7** EMPTY WT. **8** GROSS WT. **9** GVWR

VEHICLE COLOR **10** ODOMETER BRAND **11** BRANDS **12**

OWNER(S) NAME AND ADDRESS
13

SAMPLE

LIENHOLDER NAME AND ADDRESS
14

LIENHOLDER RELEASE - INTEREST IN THE VEHICLE DESCRIBED ON THIS TITLE IS HEREBY RELEASED.
15

SIGNATURE OF AUTHORIZED AGENT _____ DATE _____

PRINTED NAME OF AGENT AND COMPANY _____

FEDERAL AND STATE LAW REQUIRES THAT YOU STATE THE MILEAGE IN CONNECTION WITH THE TRANSFER OF OWNERSHIP. FAILURE TO COMPLETE OR PROVIDING A FALSE STATEMENT MAY RESULT IN FINES AND/OR IMPRISONMENT.
The undersigned hereby certifies the vehicle described in this title has been transferred to the following buyer(s):

16 _____ **17** _____ **18** AND OR

Printed Full Legal Name of Buyer Nevada Driver's License Number or Identification Number

Printed Full Legal Name of Buyer Nevada Driver's License Number or Identification Number

Address _____ City _____ State _____ Zip Code _____

I certify to the best of my knowledge the odometer reading is the actual mileage of the vehicle unless one of the following statements is checked.
19 NO TENTHS **20** The mileage stated is in excess of its mechanical limits.
The odometer reading is not the actual mileage. WARNING: ODOMETER DISCREPANCY. Except - Model year over 3 years old.

ODOMETER READING _____ **21** _____

Signature of Seller(s)/Agent/Dealership _____ Printed Name of Seller(s)/Agent/Dealership _____

I am aware of the above odometer certification made by the seller/agent. Dealer's License Number _____ **22** _____ Date of Sale _____ **23** _____

24 _____ **24** _____

Signature of Buyer _____ Printed Full Legal Name of Buyer _____

ACCORDING TO THE RECORDS OF THE DEPARTMENT OF MOTOR VEHICLES, THE PERSON NAMED HEREON IS THE OWNER OF THE VEHICLE DESCRIBED ABOVE, SUBJECT TO LIEN AS SHOWN.

VP-2 (Rev. 8/10) CONTROL NO. 00000000 (THIS IS NOT A TITLE NO.)

STATE OF NEVADA

ALTERATION OR ERASURE VOIDS THIS TITLE

Front of Title
Revised 1/2006

STATE OF NEVADA
DEPARTMENT OF MOTOR VEHICLES

CERTIFICATE OF TITLE

VIN **1** YEAR **1** MAKE **1** MODEL **1** VEHICLE BODY **1** TITLE NUMBER **2**
 DATE ISSUED **3** ODOMETER MILES **4** FUEL TYPE **5** SALES TAX PD **6** EMPTY WT **7** GROSS WT **8** GVWR **9**
 VEHICLE COLOR **10** ODOMETER BRAND **11** BRANDS **12**

OWNER(S) NAME AND ADDRESS **13**

LIENHOLDER(S) NAME AND ADDRESS **14**

LIENHOLDER(S) RELEASE - INTEREST IN THE VEHICLE DESCRIBED ON THIS TITLE IS HEREBY RELEASED: **15**

SIGNATURE OF AUTHORIZED AGENT _____ DATE _____
 PRINTED NAME OR COMPANY STAMP _____

FEDERAL AND STATE LAW REQUIRES THAT YOU STATE THE MILEAGE IN CONNECTION WITH THE TRANSFER OF OWNERSHIP. FAILURE TO COMPLETE OR PROVIDING A FALSE STATEMENT MAY RESULT IN FINES AND/OR IMPRISONMENT.
 The **16** and hereby certifies the vehicle described in this title has been transferred to the following buyer(s): **17** **18**
 Printed Full Legal Name of Buyer _____ Nevada Driver's License Number or Identification Number AND
 Printed Full Legal Name of Buyer _____ Nevada Driver's License Number or Identification Number OR

Address _____ City _____ State _____ Zip Code _____
 I certify in the best of my knowledge the odometer reading is the actual mileage of the vehicle unless one of the following statements is checked.
19 NO The mileage stated is in excess of its mechanical limits.
 ODOMETER READING **21** TENTHS The odometer reading is not the actual mileage. WARNING: ODOMETER DISCREPANCY. **20**
 Signature of Seller(s)/Agent/Dealership _____ Printed Name of Seller(s)/Agent/Dealership **21**
 I am aware of the above odometer certification made by the seller/agent. Dealer's License Number **22** Date of Sale **23**
24 Signature of Buyer _____ Printed Full Legal Name of Buyer _____
 CONTROL NO. _____
 ACCORDING TO THE RECORDS OF THE DEPARTMENT OF MOTOR VEHICLES, THE PERSON NAMED HEREON IS THE OWNER OF THE VEHICLE DESCRIBED ABOVE, SUBJECT TO LIEN AS SHOWN.
 (THIS IS NOT A TITLE NO.)
00000008

PO-2 (Rev. 1/06)

ALTERATION OR ERASURE VOIDS THIS TITLE

BACK OF TITLE

1. Dealer Only First Reassignment of Title: To be completed only by a dealer upon the first reassignment of the Certificate of Title. The dealer's business name and business license number must be recorded, and the reassignment must be completed in the same manner as the assignment on the front of the Certificate of Title.
2. Dealer Only Second Reassignment of Title: To be completed only by a dealer upon the second reassignment of the Certificate of Title. The dealer's business name and business license number must be recorded, and the reassignment must be completed in the same manner as the assignment on the front of the Certificate of Title.
3. Dealer Only Third Reassignment of Title: To be completed only by a dealer upon the third reassignment of the Certificate of Title. The dealer's business name and business license number must be recorded, and the reassignment must be completed in the same manner as the assignment on the front of the Certificate of Title.
4. Lienholder to be recorded: This section must be completed if the new Certificate of Title is to reflect a security interest in the vehicle. The lienholder's name and address must be recorded. If there is no lienholder, "None" must be recorded in this section.

Note: Any alteration or erasure voids a Nevada Certificate of Title. The reassignment on the front of the title (beginning on item 16 on the front of the title) must be completed before the Dealer Only First Reassignment of Title is completed.

**Back of Title
Revised 8/2010**

1

2

3

4

FIRST REASSIGNMENT DEALER ONLY	<p>FEDERAL AND STATE LAW REQUIRES THAT YOU STATE THE MILEAGE IN CONNECTION WITH THE TRANSFER OF OWNERSHIP. FAILURE TO COMPLETE OR PROVIDING A FALSE STATEMENT MAY RESULT IN FINES AND/OR IMPRISONMENT. The undersigned hereby certifies the vehicle described in this title has been transferred to the following buyer(s):</p>			
	Printed Full Legal Name of Buyer		Nevada Driver's License Number or Identification Number <input type="checkbox"/> AND <input type="checkbox"/> OR	
	Printed Full Legal Name of Buyer		Nevada Driver's License Number or Identification Number	
	Address	City	State	Zip Code
	<p>I certify to the best of my knowledge the odometer reading is the actual mileage of the vehicle unless one of the following statements is checked.</p>			
	<p>ODOMETER READING</p>		<p><input type="checkbox"/> NO <input type="checkbox"/> The mileage stated is in excess of its mechanical limits. <input type="checkbox"/> TENTHS <input type="checkbox"/> The odometer reading is not the actual mileage. WARNING - ODOMETER DISCREPANCY <input type="checkbox"/> Exempt - Model year over 9 yrs. old.</p>	
Signature of Seller(s)/Agent/Dealership I am aware of the above odometer certification made by the seller/agent. <input type="checkbox"/>		Printed Name of Seller(s)/Agent/Dealership Dealer's License Number _____ Date of Sale _____		
Signature of Buyer		Printed Full Legal Name of Buyer		
SECOND REASSIGNMENT DEALER ONLY	<p>FEDERAL AND STATE LAW REQUIRES THAT YOU STATE THE MILEAGE IN CONNECTION WITH THE TRANSFER OF OWNERSHIP. FAILURE TO COMPLETE OR PROVIDING A FALSE STATEMENT MAY RESULT IN FINES AND/OR IMPRISONMENT. The undersigned hereby certifies the vehicle described in this title has been transferred to the following buyer(s):</p>			
	Printed Full Legal Name of Buyer		Nevada Driver's License Number or Identification Number <input type="checkbox"/> AND <input type="checkbox"/> OR	
	Printed Full Legal Name of Buyer		Nevada Driver's License Number or Identification Number	
	Address	City	State	Zip Code
	<p>I certify to the best of my knowledge the odometer reading is the actual mileage of the vehicle unless one of the following statements is checked.</p>			
	<p>ODOMETER READING</p>		<p><input type="checkbox"/> NO <input type="checkbox"/> The mileage stated is in excess of its mechanical limits. <input type="checkbox"/> TENTHS <input type="checkbox"/> The odometer reading is not the actual mileage. WARNING - ODOMETER DISCREPANCY <input type="checkbox"/> Exempt - Model year over 9 yrs. old.</p>	
Signature of Seller(s)/Agent/Dealership I am aware of the above odometer certification made by the seller/agent. <input type="checkbox"/>		Printed Name of Seller(s)/Agent/Dealership Dealer's License Number _____ Date of Sale _____		
Signature of Buyer		Printed Full Legal Name of Buyer		
THIRD REASSIGNMENT DEALER ONLY	<p>FEDERAL AND STATE LAW REQUIRES THAT YOU STATE THE MILEAGE IN CONNECTION WITH THE TRANSFER OF OWNERSHIP. FAILURE TO COMPLETE OR PROVIDING A FALSE STATEMENT MAY RESULT IN FINES AND/OR IMPRISONMENT. The undersigned hereby certifies the vehicle described in this title has been transferred to the following buyer(s):</p>			
	Printed Full Legal Name of Buyer		Nevada Driver's License Number or Identification Number <input type="checkbox"/> AND <input type="checkbox"/> OR	
	Printed Full Legal Name of Buyer		Nevada Driver's License Number or Identification Number	
	Address	City	State	Zip Code
	<p>I certify to the best of my knowledge the odometer reading is the actual mileage of the vehicle unless one of the following statements is checked.</p>			
	<p>ODOMETER READING</p>		<p><input type="checkbox"/> NO <input type="checkbox"/> The mileage stated is in excess of its mechanical limits. <input type="checkbox"/> TENTHS <input type="checkbox"/> The odometer reading is not the actual mileage. WARNING - ODOMETER DISCREPANCY <input type="checkbox"/> Exempt - Model year over 9 yrs. old.</p>	
Signature of Seller(s)/Agent/Dealership I am aware of the above odometer certification made by the seller/agent. <input type="checkbox"/>		Printed Name of Seller(s)/Agent/Dealership Dealer's License Number _____ Date of Sale _____		
Signature of Buyer		Printed Full Legal Name of Buyer		
LIEN	LIENHOLDER TO BE RECORDED			
	Printed Full Legal Name of Lienholder		FEIN _____	
	(If no lienholder write "NONE")			
Address	Street	City	State	Zip Code

ALTERATION OR ERASURE VOIDS THIS TITLE

**Back of Title
Revised 1/2006**

1	<p>FEDERAL AND STATE LAW REQUIRES THAT YOU STATE THE MILEAGE IN CONNECTION WITH THE TRANSFER OF OWNERSHIP. FAILURE TO COMPLETE OR PROVIDING A FALSE STATEMENT MAY RESULT IN FINES AND/OR IMPRISONMENT.</p> <p>The undersigned hereby certifies the vehicle described in this title has been transferred to the following buyer(s):</p>
FIRST REASSIGNMENT DEALER ONLY	Printed Full Legal Name of Buyer _____ Nevada Driver's License Number or Identification Number _____ <input type="checkbox"/> AND <input type="checkbox"/> OR
	Printed Full Legal Name of Buyer _____ Nevada Driver's License Number or Identification Number _____
	Address _____ City _____ State _____ Zip Code _____
	I certify to the best of my knowledge the odometer reading is the actual mileage of the vehicle unless one of the following statements is checked.
	<input type="checkbox"/> NO TENTHS <input type="checkbox"/> The mileage stated is in excess of its mechanical limits. <input type="checkbox"/> The odometer reading is not the actual mileage. WARNING - ODOMETER DISCREPANCY <input type="checkbox"/> Exempt - Model year over 9 yrs. old.
	ODOMETER READING _____ Signature of Seller(s)/Agent/Dealership _____ Printed Name of Seller(s)/Agent/Dealership _____ I am aware of the above odometer certification made by the seller/agent. <input type="checkbox"/> Dealer's License Number _____ Date of Sale _____ Signature of Buyer _____ Printed Full Legal Name of Buyer _____
2	<p>FEDERAL AND STATE LAW REQUIRES THAT YOU STATE THE MILEAGE IN CONNECTION WITH THE TRANSFER OF OWNERSHIP. FAILURE TO COMPLETE OR PROVIDING A FALSE STATEMENT MAY RESULT IN FINES AND/OR IMPRISONMENT.</p> <p>The undersigned hereby certifies the vehicle described in this title has been transferred to the following buyer(s):</p>
SECOND REASSIGNMENT DEALER ONLY	Printed Full Legal Name of Buyer _____ Nevada Driver's License Number or Identification Number _____ <input type="checkbox"/> AND <input type="checkbox"/> OR
	Printed Full Legal Name of Buyer _____ Nevada Driver's License Number or Identification Number _____
	Address _____ City _____ State _____ Zip Code _____
	I certify to the best of my knowledge the odometer reading is the actual mileage of the vehicle unless one of the following statements is checked.
	<input type="checkbox"/> NO TENTHS <input type="checkbox"/> The mileage stated is in excess of its mechanical limits. <input type="checkbox"/> The odometer reading is not the actual mileage. WARNING - ODOMETER DISCREPANCY <input type="checkbox"/> Exempt - Model year over 9 yrs. old.
	ODOMETER READING _____ Signature of Seller(s)/Agent/Dealership _____ Printed Name of Seller(s)/Agent/Dealership _____ I am aware of the above odometer certification made by the seller/agent. <input type="checkbox"/> Dealer's License Number _____ Date of Sale _____ Signature of Buyer _____ Printed Full Legal Name of Buyer _____
3	<p>FEDERAL AND STATE LAW REQUIRES THAT YOU STATE THE MILEAGE IN CONNECTION WITH THE TRANSFER OF OWNERSHIP. FAILURE TO COMPLETE OR PROVIDING A FALSE STATEMENT MAY RESULT IN FINES AND/OR IMPRISONMENT.</p> <p>The undersigned hereby certifies the vehicle described in this title has been transferred to the following buyer(s):</p>
THIRD REASSIGNMENT DEALER ONLY	Printed Full Legal Name of Buyer _____ Nevada Driver's License Number or Identification Number _____ <input type="checkbox"/> AND <input type="checkbox"/> OR
	Printed Full Legal Name of Buyer _____ Nevada Driver's License Number or Identification Number _____
	Address _____ City _____ State _____ Zip Code _____
	I certify to the best of my knowledge the odometer reading is the actual mileage of the vehicle unless one of the following statements is checked.
	<input type="checkbox"/> NO TENTHS <input type="checkbox"/> The mileage stated is in excess of its mechanical limits. <input type="checkbox"/> The odometer reading is not the actual mileage. WARNING - ODOMETER DISCREPANCY <input type="checkbox"/> Exempt - Model year over 9 yrs. old.
	ODOMETER READING _____ Signature of Seller(s)/Agent/Dealership _____ Printed Name of Seller(s)/Agent/Dealership _____ I am aware of the above odometer certification made by the seller/agent. <input type="checkbox"/> Dealer's License Number _____ Date of Sale _____ Signature of Buyer _____ Printed Full Legal Name of Buyer _____
4	<p>LIENHOLDER TO BE RECORDED</p> <p style="text-align: right;">FEIN _____</p>
LIEN	Printed Full Legal Name of Lienholder _____ (if no lienholder write "NONE")
	Address _____ Street _____ City _____ State _____ Zip Code _____

ALTERATION OR ERASURE VOIDS THIS TITLE

NEVADA SALVAGE TITLE (FORM VP-2S)

Salvage Title (NAC 487.007) means a certificate of title issued by the state agency pursuant to NRS 487.810.

The Department will issue a Salvage Title for a vehicle upon application to the:

- Legal owner of the vehicle;
- The person to whom the vehicle is titled;
- An insurance company that acquires the vehicle as a salvage vehicle; or
- A lienholder who acquires title to the vehicle.

If the Certificate of Title/Ownership is held by a lienholder, the registered owner must notify the lienholder within 10 days that the vehicle has become a salvage vehicle. The lienholder must, within 30 days of receiving the notice, forward the title and the Application for Salvage Title or Non-Repairable Vehicle Certificate (Form VP-213) to the Department. See page II-16 for more information on form VP-213.

An Application for Salvage Title or Non-Repairable Vehicle Certificate (Form VP-213) and all accompanying documents will be returned to the applicant if they are not correctly completed in full.

Salvage Title Fees:

- | | |
|---|---------|
| • Licensed Nevada Automobile Wrecker | No fee |
| • Out-of-State Automobile Wrecker | \$10.00 |
| • Licensed Nevada Salvage Pool | \$10.00 |
| • In-State or Out-of-State Insurance Companies | \$10.00 |
| • Out-of-State Vehicle Dealers (must be registered with a Salvage Pool) | \$10.00 |

An owner of a salvage vehicle may only sell the salvage vehicle to a salvage pool, automobile auction, rebuilder, automobile wrecker, or a new or used automobile dealer.

The Authorization for Vehicle Restoration must be obtained prior to the vehicle being rebuilt for vehicles five years old or newer. The vehicle must be repaired or restored to operation, complete a VP-64 and have a branded title before the vehicle may be sold to a person other than the businesses listed.

The fields are the same as on the Nevada Certificate of Title.

**Front of Salvage Title
Revised 8/2010**

STATE OF NEVADA
DEPARTMENT OF MOTOR VEHICLES

SALVAGE TITLE

VIN	YEAR	MAKE	MODEL	VEHICLE BODY	TITLE NUMBER
DATE ISSUED	ODOMETER MILES	FUEL TYPE	SALES TAX PD	EMPTY WT	GROSS WT
VEHICLE COLOR	ODOMETER BRAND	BRANDS			

OWNER(S) NAME AND ADDRESS

SAMPLE

LIENHOLDER NAME AND ADDRESS

LIENHOLDER RELEASE - INTEREST IN THE VEHICLE DESCRIBED ON THIS TITLE IS HEREBY RELEASED.

SIGNATURE OF AUTHORIZED AGENT _____ DATE _____

PRINTED NAME OF AGENT AND COMPANY _____

FEDERAL AND STATE LAW REQUIRES THAT YOU STATE THE MILEAGE IN CONNECTION WITH THE TRANSFER OF OWNERSHIP. FAILURE TO COMPLETE OR PROVIDING A FALSE STATEMENT MAY RESULT IN FINES AND/OR IMPRISONMENT.
The undersigned hereby certifies the vehicle described in this title has been transferred to the following buyer(s):

Printed Full Legal Name of Buyer _____ Nevada Driver's License Number or Identification Number AND OR

Printed Full Legal Name of Buyer _____ Nevada Driver's License Number or Identification Number _____

Address _____ City _____ State _____ Zip Code _____

I certify to the best of my knowledge the odometer reading is the actual mileage of the vehicle unless one of the following statements is checked.
 NO TENTHS The mileage stated is in excess of its mechanical limits.
 The odometer reading is not the actual mileage. WARNING: ODOMETER DISCREPANCY. Exempt - Model year over 5 years old.

ODOMETER READING _____

Signature of Seller/Agent/Dealership _____ Printed Name of Seller/Agent/Dealership _____

I am aware of the above odometer certification made by the seller/agent. Dealer's License Number _____ Date of Sale _____

Signature of Buyer _____ Printed Full Legal Name of Buyer _____

ACCORDING TO THE RECORDS OF THE DEPARTMENT OF MOTOR VEHICLES, THE PERSON NAMED HEREON IS THE OWNER OF THE VEHICLE DESCRIBED ABOVE, SUBJECT TO LIEN AS SHOWN.

VP-23 (Rev. 8/10)

CONTROL NO.
5000000
(THIS IS NOT A TITLE NO.)

STATE OF NEVADA

ALTERATION OR ERASURE VOIDS THIS TITLE

Front of Salvage Title
Revised 1/2006

STATE OF NEVADA
DEPARTMENT OF MOTOR VEHICLES

SALVAGE TITLE

VIN	YEAR	MAKE	MODEL	VEHICLE BODY	TITLE NUMBER
DATE ISSUED	ODOMETER MILES	FUEL TYPE	SALES TAX PD	EMPTY WT	GROSS WT
VEHICLE COLOR	ODOMETER BRAND	BRANDS			

OWNER(S) NAME AND ADDRESS

SAMPLE

LIENHOLDER(S) NAME AND ADDRESS

LIENHOLDER(S) RELEASE – INTEREST IN THE VEHICLE DESCRIBED ON THIS TITLE IS HEREBY RELEASED:

SIGNATURE OF AUTHORIZED AGENT _____ DATE _____

PRINTED NAME OR COMPANY STAMP _____

FEDERAL AND STATE LAW REQUIRES THAT YOU STATE THE MILEAGE IN CONNECTION WITH THE TRANSFER OF OWNERSHIP. FAILURE TO COMPLETE OR PROVIDING A FALSE STATEMENT MAY RESULT IN FINES AND/OR IMPRISONMENT.
The undersigned hereby certifies the vehicle described in this title has been transferred to the following buyer(s):

Printed Full Legal Name of Buyer _____ Nevada Driver's License Number or Identification Number AND OR

Printed Full Legal Name of Buyer _____ Nevada Driver's License Number or Identification Number _____

Address _____ City _____ State _____ Zip Code _____

I certify to the best of my knowledge the odometer reading is the actual mileage of the vehicle unless one of the following statements is checked.

ODOMETER READING NO TENTHS The mileage stated is in excess of its mechanical limits. The odometer reading is not the actual mileage. **WARNING: ODOMETER DISCREPANCY.** Exempt - Model year over 9 years old.

Signature of Seller(s)/Agent/Dealership _____ Printed Name of Seller(s)/Agent/Dealership _____

I am aware of the above odometer certification made by the seller/agent. Dealer's License Number _____ Date of Sale _____

Signature of Buyer _____ Printed Full Legal Name of Buyer _____

ACCORDING TO THE RECORDS OF THE DEPARTMENT OF MOTOR VEHICLES, THE PERSON NAMED HEREON IS THE OWNER OF THE VEHICLE DESCRIBED ABOVE, SUBJECT TO LIEN AS SHOWN.

CONTROL NO.

(THIS IS NOT A TITLE NO.)
500000

ALTERATION OR ERASURE, VOIDS THIS TITLE

Back of Salvage Title Revised 8/2010

▶	FEDERAL AND STATE LAW REQUIRES THAT YOU STATE THE MILEAGE IN CONNECTION WITH THE TRANSFER OF OWNERSHIP. FAILURE TO COMPLETE OR PROVIDING A FALSE STATEMENT MAY RESULT IN FINES AND/OR IMPRISONMENT. The undersigned hereby certifies the vehicle described in this title has been transferred to the following buyer(s):			
FIRST REASSIGNMENT DEALER ONLY	Printed Full Legal Name of Buyer _____	Nevada Driver's License Number or Identification Number _____	<input type="checkbox"/> AND	
	Printed Full Legal Name of Buyer _____	Nevada Driver's License Number or Identification Number _____	<input type="checkbox"/> OR	
	Address _____	City _____	State _____	Zip Code _____
	I certify to the best of my knowledge the odometer reading is the actual mileage of the vehicle unless one of the following statements is checked.			
	ODOMETER READING _____	<input type="checkbox"/> NO TENTHS <input type="checkbox"/> TENTHS	<input type="checkbox"/> The mileage stated is in excess of its mechanical limits. <input type="checkbox"/> The odometer reading is not the actual mileage. WARNING - ODOMETER DISCREPANCY Exempt - Model year over 9 yrs. old.	
	Signature of Seller(s)/Agent/Dealership _____ I am aware of the above odometer certification made by the seller/agent. <input type="checkbox"/>		Printed Name of Seller(s)/Agent/Dealership _____ Dealer's License Number _____ Date of Sale _____	
Signature of Buyer _____		Printed Full Legal Name of Buyer _____		
▶	FEDERAL AND STATE LAW REQUIRES THAT YOU STATE THE MILEAGE IN CONNECTION WITH THE TRANSFER OF OWNERSHIP. FAILURE TO COMPLETE OR PROVIDING A FALSE STATEMENT MAY RESULT IN FINES AND/OR IMPRISONMENT. The undersigned hereby certifies the vehicle described in this title has been transferred to the following buyer(s):			
SECOND REASSIGNMENT DEALER ONLY	Printed Full Legal Name of Buyer _____	Nevada Driver's License Number or Identification Number _____	<input type="checkbox"/> AND	
	Printed Full Legal Name of Buyer _____	Nevada Driver's License Number or Identification Number _____	<input type="checkbox"/> OR	
	Address _____	City _____	State _____	Zip Code _____
	I certify to the best of my knowledge the odometer reading is the actual mileage of the vehicle unless one of the following statements is checked.			
	ODOMETER READING _____	<input type="checkbox"/> NO TENTHS <input type="checkbox"/> TENTHS	<input type="checkbox"/> The mileage stated is in excess of its mechanical limits. <input type="checkbox"/> The odometer reading is not the actual mileage. WARNING - ODOMETER DISCREPANCY Exempt - Model year over 9 yrs. old.	
	Signature of Seller(s)/Agent/Dealership _____ I am aware of the above odometer certification made by the seller/agent. <input type="checkbox"/>		Printed Name of Seller(s)/Agent/Dealership _____ Dealer's License Number _____ Date of Sale _____	
Signature of Buyer _____		Printed Full Legal Name of Buyer _____		
▶	FEDERAL AND STATE LAW REQUIRES THAT YOU STATE THE MILEAGE IN CONNECTION WITH THE TRANSFER OF OWNERSHIP. FAILURE TO COMPLETE OR PROVIDING A FALSE STATEMENT MAY RESULT IN FINES AND/OR IMPRISONMENT. The undersigned hereby certifies the vehicle described in this title has been transferred to the following buyer(s):			
THIRD REASSIGNMENT DEALER ONLY	Printed Full Legal Name of Buyer _____	Nevada Driver's License Number or Identification Number _____	<input type="checkbox"/> AND	
	Printed Full Legal Name of Buyer _____	Nevada Driver's License Number or Identification Number _____	<input type="checkbox"/> OR	
	Address _____	City _____	State _____	Zip Code _____
	I certify to the best of my knowledge the odometer reading is the actual mileage of the vehicle unless one of the following statements is checked.			
	ODOMETER READING _____	<input type="checkbox"/> NO TENTHS <input type="checkbox"/> TENTHS	<input type="checkbox"/> The mileage stated is in excess of its mechanical limits. <input type="checkbox"/> The odometer reading is not the actual mileage. WARNING - ODOMETER DISCREPANCY Exempt - Model year over 9 yrs. old.	
	Signature of Seller(s)/Agent/Dealership _____ I am aware of the above odometer certification made by the seller/agent. <input type="checkbox"/>		Printed Name of Seller(s)/Agent/Dealership _____ Dealer's License Number _____ Date of Sale _____	
Signature of Buyer _____		Printed Full Legal Name of Buyer _____		
▶	LIENHOLDER TO BE RECORDED			
LIEN	Printed Full Legal Name of Lienholder _____			FEIN _____
	(if no lienholder enter "NONE")			
	Address _____	Street _____	City _____	State _____ Zip Code _____

ALTERATION OR ERASURE VOIDS THIS TITLE

Back of Salvage Title Revised 1/2006

▶	FEDERAL AND STATE LAW REQUIRES THAT YOU STATE THE MILEAGE IN CONNECTION WITH THE TRANSFER OF OWNERSHIP. FAILURE TO COMPLETE OR PROVIDING A FALSE STATEMENT MAY RESULT IN FINES AND/OR IMPRISONMENT. The undersigned hereby certifies the vehicle described in this title has been transferred to the following buyer(s):				
FIRST REASSIGNMENT DEALER ONLY	Printed Full Legal Name of Buyer _____		Nevada Driver's License Number or Identification Number _____ <input type="checkbox"/> AND <input type="checkbox"/> OR		
	Printed Full Legal Name of Buyer _____		Nevada Driver's License Number or Identification Number _____		
	Address _____		City _____	State _____	Zip Code _____
	I certify to the best of my knowledge the odometer reading is the actual mileage of the vehicle unless one of the following statements is checked. The mileage stated is in excess of its mechanical limits. <input type="checkbox"/> The odometer reading is not the actual mileage. WARNING - ODOMETER DISCREPANCY Example - Model year over 9 yrs. old. <input type="checkbox"/>				
	ODOMETER READING _____		NO TENTHS <input type="checkbox"/>		
	Signature of Seller(s)/Agent/Dealership _____ I am aware of the above odometer certification made by the seller/agent. <input type="checkbox"/>		Printed Name of Seller(s)/Agent/Dealership _____ Dealer's License Number _____ Date of Sale _____		
Signature of Buyer _____		Printed Full Legal Name of Buyer _____			
▶	FEDERAL AND STATE LAW REQUIRES THAT YOU STATE THE MILEAGE IN CONNECTION WITH THE TRANSFER OF OWNERSHIP. FAILURE TO COMPLETE OR PROVIDING A FALSE STATEMENT MAY RESULT IN FINES AND/OR IMPRISONMENT. The undersigned hereby certifies the vehicle described in this title has been transferred to the following buyer(s):				
SECOND REASSIGNMENT DEALER ONLY	Printed Full Legal Name of Buyer _____		Nevada Driver's License Number or Identification Number _____ <input type="checkbox"/> AND <input type="checkbox"/> OR		
	Printed Full Legal Name of Buyer _____		Nevada Driver's License Number or Identification Number _____		
	Address _____		City _____	State _____	Zip Code _____
	I certify to the best of my knowledge the odometer reading is the actual mileage of the vehicle unless one of the following statements is checked. The mileage stated is in excess of its mechanical limits. <input type="checkbox"/> The odometer reading is not the actual mileage. WARNING - ODOMETER DISCREPANCY Example - Model year over 9 yrs. old. <input type="checkbox"/>				
	ODOMETER READING _____		NO TENTHS <input type="checkbox"/>		
	Signature of Seller(s)/Agent/Dealership _____ I am aware of the above odometer certification made by the seller/agent. <input type="checkbox"/>		Printed Name of Seller(s)/Agent/Dealership _____ Dealer's License Number _____ Date of Sale _____		
Signature of Buyer _____		Printed Full Legal Name of Buyer _____			
▶	FEDERAL AND STATE LAW REQUIRES THAT YOU STATE THE MILEAGE IN CONNECTION WITH THE TRANSFER OF OWNERSHIP. FAILURE TO COMPLETE OR PROVIDING A FALSE STATEMENT MAY RESULT IN FINES AND/OR IMPRISONMENT. The undersigned hereby certifies the vehicle described in this title has been transferred to the following buyer(s):				
THIRD REASSIGNMENT DEALER ONLY	Printed Full Legal Name of Buyer _____		Nevada Driver's License Number or Identification Number _____ <input type="checkbox"/> AND <input type="checkbox"/> OR		
	Printed Full Legal Name of Buyer _____		Nevada Driver's License Number or Identification Number _____		
	Address _____		City _____	State _____	Zip Code _____
	I certify to the best of my knowledge the odometer reading is the actual mileage of the vehicle unless one of the following statements is checked. The mileage stated is in excess of its mechanical limits. <input type="checkbox"/> The odometer reading is not the actual mileage. WARNING - ODOMETER DISCREPANCY Example - Model year over 9 yrs. old. <input type="checkbox"/>				
	ODOMETER READING _____		NO TENTHS <input type="checkbox"/>		
	Signature of Seller(s)/Agent/Dealership _____ I am aware of the above odometer certification made by the seller/agent. <input type="checkbox"/>		Printed Name of Seller(s)/Agent/Dealership _____ Dealer's License Number _____ Date of Sale _____		
Signature of Buyer _____		Printed Full Legal Name of Buyer _____			
LIEN	LIENHOLDER TO BE RECORDED				
	Printed Full Legal Name of Lienholder _____ (if no lienholder write "NONE")		FBN _____		
Address _____		Street _____	City _____	State _____ Zip Code _____	

ALTERATION OR ERASURE VOIDS THIS TITLE

Out-of-State Salvage Certificates

Salvage titles issued by other states must be properly endorsed and must indicate and document a complete “chain of ownership” for the vehicle.

Contact the Department prior to accepting documents for a salvaged or junked vehicle, as laws from other states vary, and there may be instances where the Department must determine whether the documents can be accepted and whether a Salvage Title can be issued.

Retention of Salvage Vehicles

An insured party (registered owner) may elect to retain a vehicle that has been declared a total loss insurance settlement. The insurance company or authorized agent must obtain the signature of the registered owner on the Application for Salvage Title or Non-Repairable Vehicle Certificate.

The insurance company must apply for a Salvage Title on behalf of the person who is retaining the salvage vehicle. The vehicle may not be sold or transferred until the registered owner has received a Salvage Title.

An owner of a total loss salvage vehicle may sell the vehicle with the properly endorsed certificate of title, without making any repairs to the vehicle, only to a salvage pool, automobile auction, rebuilder, automobile wrecker, or a new or used motor vehicle dealer.

Non-Repairable Vehicle Certificate

A Non-Repairable Vehicle is defined as a motor vehicle, other than an abandoned vehicle that:

1. Has value only as a source of parts or scrap metal;
2. Has been designated by its owner for dismantling as a source of parts or scrap metal;
3. Has been stripped of all body panels, doors, hatches, substantially all interior components and substantially all grill and light assemblies; or
4. Has been burned, destroyed, or otherwise damaged to such an extent that it cannot be returned to a condition which is legal for operation on the highways of this state.

A Non-Repairable Vehicle Certificate will be issued, upon application, for a vehicle as described in the definition (follow directions for Application for Salvage Title or Non-Repairable Vehicle Certificate). A Non-Repairable Vehicle Certificate must be issued before the ownership interest in a non-repairable vehicle may be transferred.

Once a vehicle has been issued a Non-Repairable Vehicle Certificate, the vehicle may not be registered or issued a Certificate of Title, or be restored for use on Nevada highways.

A vehicle for which a Non-Repairable Vehicle Certificate has been issued may not apply for or be issued a Salvage Title.

Transfer of ownership for a Non-Repairable Vehicle may only occur between a licensed automobile wrecker, dismantler, or recycler. A licensed automobile wrecker, dismantler, or recycler may only process a Non-Repairable Vehicle as parts or scrap metal.

A Duplicate Non-Repairable Vehicle Certificate may be issued by completing an Application for Salvage Title or Non-Repairable Vehicle Certificate, checking the transaction type box, indicating "Duplicate."

No fee is assessed for a Non-Repairable Vehicle Certificate.

Non-Repairable Vehicle Certificate
VP-261 is one sided on standard white paper
Revised 1/2012



555 WRIGHT WAY
 CARSON CITY, NV 89711-0700
 Reno/Sparks/Carson City (775) 684-4DMV (4368)
 Las Vegas Area (702) 486-4DMV (4366)
 Rural Nevada or Out of State (877) 368-7828
www.dmvnv.com

NON-REPAIRABLE VEHICLE CERTIFICATE

This Non-Repairable Vehicle Certificate is an official ownership document issued by the Nevada Department of Motor Vehicles. The owner named hereon is the owner of the vehicle described below.

Vehicle Identification Number _____ Title Number _____ Date _____

Year _____ Make _____ Model _____ Body Type _____

Axes _____ Length _____ Brands _____

Odometer Reading _____ Odometer Brand _____

Owner Information - Full Legal Name _____

Nevada DMV Business License Number _____

Mailing Address _____

Release of Ownership - STATE LAW PROHIBITS THIS NON-REPAIRABLE VEHICLE FROM BEING REBUILT, RECONSTRUCTED, OR REBUILT FOR OPERATING ON THE HIGHWAYS OF NEVADA. THIS VEHICLE MAY ONLY BE PROCESSED AS PARTS AND/OR SCRAP METAL BY A LICENSE AUTOMOBILE WRECKER, DISMANTLER, OR RECYCLER. The undersigned hereby releases the vehicle described in this title has been transferred to the following buyer(s):

Printed Full Legal Name _____ Nevada DMV Business License Number _____

Address _____ City _____ State _____ Zip Code _____

I certify to the best of my knowledge the odometer reading is the actual mileage of the vehicle unless one of the following statements is checked:
 ODOMETER READING: NO TENTHS
 The mileage stated is in excess of its mechanical limit.
 The odometer reading is not the actual mileage. **WARNING - ODOMETER DISCREPANCY.**
 (except - Motor year over 9 yrs. old)

Signature of Seller _____ Printed Name of Buyer _____

I am aware of the above odometer certification made by the seller(s) Nevada DMV Business License Number _____ Date of Sale _____

Signature of Buyer _____ Printed Full Legal Name of Buyer _____

Reassignment

Printed Full Legal Name of Buyer _____ Nevada DMV Business License Number _____

Address _____ City _____ State _____ Zip Code _____

I certify to the best of my knowledge the odometer reading is the actual mileage of the vehicle unless one of the following statements is checked:
 ODOMETER READING: NO TENTHS
 The mileage stated is in excess of its mechanical limit.
 The odometer reading is not the actual mileage. **WARNING - ODOMETER DISCREPANCY.**
 (except - Motor year over 9 yrs. old)

Signature of Seller _____ Printed Name of Buyer _____

I am aware of the above odometer certification made by the seller(s) Nevada DMV Business License Number _____ Date of Sale _____

Signature of Buyer _____ Printed Full Legal Name of Buyer _____

**Front of Non-Repairable Vehicle Certificate
Printed on green paper
Revised 8/2003**

STATE OF NEVADA
DEPARTMENT OF MOTOR VEHICLES

NON-REPAIRABLE VEHICLE CERTIFICATE

VIN	YEAR	MAKE	MODEL	VEHICLE BODY	TITLE NUMBER	
DATE ISSUED	ODOMETER MILES	FUEL TYPE	SALES TAX PD.	EMPTY WT.	GROSS WT.	GWWR
VEHICLE COLOR	ODOMETER BRAND		BRANDS			

OWNER(S) NAME AND ADDRESS



STATE LAW PROHIBITS THIS NON-REPAIRABLE VEHICLE FROM BEING REBUILT, RECONSTRUCTED, OR RESTORED FOR OPERATING ON THE HIGHWAYS OF NEVADA. THIS VEHICLE MAY ONLY BE PROCESSED AS PARTS AND SCRAP METAL BY A LICENSED AUTOMOBILE WRECKER, DISMANTLER, OR RECYCLER.

ACCORDING TO THE RECORDS OF THE DEPARTMENT OF MOTOR VEHICLES, THE PERSON NAMED HEREON IS THE OWNER OF THE VEHICLE DESCRIBED ABOVE.

CONTROL NO. 000500

RD-2NR 8/2003 (NSPO 8-03) (0) 4399 (THIS IS NOT A TITLE)

ALTERATION OR ERASURE VOIDS THIS CERTIFICATE

Back of Non-Repairable Vehicle Certificate
Printed on green paper
Revised 8/2003

Form with three sections: FIRST TRANSFER OF CERTIFICATE TO A LICENSED AUTO WRECKER, DISMANTLER, OR RECYCLER; SECOND TRANSFER OF CERTIFICATE TO A LICENSED AUTO WRECKER, DISMANTLER, OR RECYCLER; THIRD TRANSFER OF CERTIFICATE TO A LICENSED AUTO WRECKER, DISMANTLER, OR RECYCLER. Each section includes fields for Buyer and Seller names, signatures, license numbers, odometer readings, and dates of sale/transfer. Includes a disclaimer at the bottom: ALTERATION OR ERASURE VOIDS THIS CERTIFICATE.

Junk Certificate (VP-161) NRS 487.260

- The vehicle must have been acquired pursuant to NRS 487.230, removal of abandoned vehicles. Abandoned Vehicle verification must be presented by a written tow request from law enforcement for removal on public property.
- Vehicles must have a vehicle identification number that can be located. Partial vehicles or component parts are not considered a vehicle. A vehicle without an identifiable VIN should not be appraised or issued a “junk certificate” unless the vehicle can be identified through the confidential VIN or other means.
- The skeleton of a vehicle body having essentially all its major exterior and interior component parts removed including all identifying numbers may be considered, after examination by a Department representative or law enforcement officer, a part of a vehicle or scrap metal. A junk certificate would not be issued for such a part of a vehicle.
- Vehicles must be ruined, wrecked, dismantled, or rendered inoperative.
- Vehicle must be unfit for further use in accordance with the original purpose for which it was constructed.
- Vehicle must not be currently registered with the Department.
- If acquired by a tow company or wrecker as an abandoned vehicle and appraised by a Department representative at \$200 or less and has not been reclaimed by the registered owner or a person having a security interest in the vehicle within 15 days after notification pursuant to NRS 487.250.

Upon appraisal, if the vehicle meets all requirements a “Junk Certificate” may immediately be issued.

There is no fee for a junk certificate.

Front of Junk Certificate Revised 5-2011



555 Wright Way
Carson City, NV 89711
Reno/Sparks/Carson City (775) 684-4DMV (4368)
Las Vegas area (702) 486-4DMV (4368)
Rural Nevada or Out of State (877) 368-7828
www.dmvnv.com

APPRAISAL REPORT FOR ABANDONED VEHICLE or
 JUNK CERTIFICATE
NRS 487.260

Please print or type

Wrecker or Tow Company and FEIN or License number:		Address:	
<input type="checkbox"/> Original <input type="checkbox"/> Re-Assignment		Location Towed From:	
Authorizing Authority:		Odometer Reading:	
Year:	Make:	Body Type:	Model:
Color:		License Plate No. <input type="checkbox"/> One <input type="checkbox"/> Two	
Expiration Month/Year:		State:	
VIN: _____			

Engine Components and Drive Train	Present	Damaged	Missing	Body	Present	Damaged	Missing
Engine Block	<input type="checkbox"/>	<input type="checkbox"/>	<input type="checkbox"/>	Left Front Fender	<input type="checkbox"/>	<input type="checkbox"/>	<input type="checkbox"/>
Heads	<input type="checkbox"/>	<input type="checkbox"/>	<input type="checkbox"/>	Left Rear Fender	<input type="checkbox"/>	<input type="checkbox"/>	<input type="checkbox"/>
Carburetor/Fuel Injector	<input type="checkbox"/>	<input type="checkbox"/>	<input type="checkbox"/>	Right Front Fender	<input type="checkbox"/>	<input type="checkbox"/>	<input type="checkbox"/>
Radiator	<input type="checkbox"/>	<input type="checkbox"/>	<input type="checkbox"/>	Right Rear Fender	<input type="checkbox"/>	<input type="checkbox"/>	<input type="checkbox"/>
Transmission	<input type="checkbox"/>	<input type="checkbox"/>	<input type="checkbox"/>	Hood	<input type="checkbox"/>	<input type="checkbox"/>	<input type="checkbox"/>
Transfer Case	<input type="checkbox"/>	<input type="checkbox"/>	<input type="checkbox"/>	Trunk Lid/Tailgate	<input type="checkbox"/>	<input type="checkbox"/>	<input type="checkbox"/>
Air Conditioning	<input type="checkbox"/>	<input type="checkbox"/>	<input type="checkbox"/>	Grill	<input type="checkbox"/>	<input type="checkbox"/>	<input type="checkbox"/>
				Bumper(s)	<input type="checkbox"/>	<input type="checkbox"/>	<input type="checkbox"/>

4 or more items listed as present indicate a viable resource.

5 or more items listed as present indicate a viable resource.

Interior	Present	Damaged	Missing	Frame and Suspension	Present	Damaged	Missing
Seats	<input type="checkbox"/>	<input type="checkbox"/>	<input type="checkbox"/>	Frame	<input type="checkbox"/>	<input type="checkbox"/>	<input type="checkbox"/>
Dash	<input type="checkbox"/>	<input type="checkbox"/>	<input type="checkbox"/>	Driveline(s)	<input type="checkbox"/>	<input type="checkbox"/>	<input type="checkbox"/>
Instruments	<input type="checkbox"/>	<input type="checkbox"/>	<input type="checkbox"/>	Axle(s)	<input type="checkbox"/>	<input type="checkbox"/>	<input type="checkbox"/>
Radio	<input type="checkbox"/>	<input type="checkbox"/>	<input type="checkbox"/>	Springs/Struts	<input type="checkbox"/>	<input type="checkbox"/>	<input type="checkbox"/>
Steering Column	<input type="checkbox"/>	<input type="checkbox"/>	<input type="checkbox"/>				

4 or more items listed as present indicate a viable resource.

3 or more items listed as present indicate a viable resource.

I certify the vehicle described above was obtained in the condition documented by this appraisal on the date of inspection.

I, the undersigned, have inspected the above vehicle, per NRS 487.240, and to the best of my knowledge and belief the estimated appraised value is:

Appraised Value:

1. Exceeds \$500.00
2. Between \$200.00 and \$500.00
3. Under \$200.00

Printed Name of Wrecker or Tow Company Representative

Signature of Wrecker or Tow Company Representative

Remarks: _____

Control No.

Printed Name of Authorized Representative

Signature of Authorized Representative Date

DMV Office Address

Front of Junk Certificate Revised 5-2010



555 Wright Way
Carson City, NV 89711
Reno/Sparks/Carson City (775) 684-4DMV (4368)
Las Vegas area (702) 486-4DMV (4368)
Rural Nevada or Out of State (877) 368-7828
www.dmvnv.com

APPRAISAL REPORT FOR ABANDONED VEHICLE
OR
 JUNK CERTIFICATE
NRS 487.260

Please print or type

Wrecker or Tow Company <i>and FEIN or License number.</i>				Address:			
<input type="checkbox"/> Original <input type="checkbox"/> Re-Assignment		Location Towed From:			Authorizing Authority:		
Year:	Make:	Body Type:	Model:	Color:	Odometer Reading:		
VIN:				License Plate No.	<input type="checkbox"/> One <input type="checkbox"/> Two	Expiration Month/Year:	State:

<u>Engine Components and Drive Train</u>	Present	Damaged	Missing	<u>Body</u>	Present	Damaged	Missing
Engine Block	<input type="checkbox"/>	<input type="checkbox"/>	<input type="checkbox"/>	Left Front Fender	<input type="checkbox"/>	<input type="checkbox"/>	<input type="checkbox"/>
Heads	<input type="checkbox"/>	<input type="checkbox"/>	<input type="checkbox"/>	Left Rear Fender	<input type="checkbox"/>	<input type="checkbox"/>	<input type="checkbox"/>
Carburetor/Fuel Injector	<input type="checkbox"/>	<input type="checkbox"/>	<input type="checkbox"/>	Right Front Fender	<input type="checkbox"/>	<input type="checkbox"/>	<input type="checkbox"/>
Radiator	<input type="checkbox"/>	<input type="checkbox"/>	<input type="checkbox"/>	Right Rear Fender	<input type="checkbox"/>	<input type="checkbox"/>	<input type="checkbox"/>
Transmission	<input type="checkbox"/>	<input type="checkbox"/>	<input type="checkbox"/>	Hood	<input type="checkbox"/>	<input type="checkbox"/>	<input type="checkbox"/>
Transfer Case	<input type="checkbox"/>	<input type="checkbox"/>	<input type="checkbox"/>	Trunk Lid/Tailgate	<input type="checkbox"/>	<input type="checkbox"/>	<input type="checkbox"/>
Air Conditioning	<input type="checkbox"/>	<input type="checkbox"/>	<input type="checkbox"/>	Grill	<input type="checkbox"/>	<input type="checkbox"/>	<input type="checkbox"/>
				Bumper(s)	<input type="checkbox"/>	<input type="checkbox"/>	<input type="checkbox"/>

4 or more items listed as present indicate a viable resource. 5 or more items listed as present indicate a viable resource.

<u>Interior</u>	Present	Damaged	Missing	<u>Frame and Suspension</u>	Present	Damaged	Missing
Seats	<input type="checkbox"/>	<input type="checkbox"/>	<input type="checkbox"/>	Frame	<input type="checkbox"/>	<input type="checkbox"/>	<input type="checkbox"/>
Dash	<input type="checkbox"/>	<input type="checkbox"/>	<input type="checkbox"/>	Driveline(s)	<input type="checkbox"/>	<input type="checkbox"/>	<input type="checkbox"/>
Instruments	<input type="checkbox"/>	<input type="checkbox"/>	<input type="checkbox"/>	Axle(s)	<input type="checkbox"/>	<input type="checkbox"/>	<input type="checkbox"/>
Radio	<input type="checkbox"/>	<input type="checkbox"/>	<input type="checkbox"/>	Springs/Struts	<input type="checkbox"/>	<input type="checkbox"/>	<input type="checkbox"/>
Steering Column	<input type="checkbox"/>	<input type="checkbox"/>	<input type="checkbox"/>				

4 or more items listed as present indicate a viable resource. 3 or more items listed as present indicate a viable resource.

I certify the vehicle described above was obtained in the condition documented by this appraisal on the date of inspection.

I, the undersigned, have inspected the above vehicle, per NRS 487.240, and to the best of my knowledge and belief the estimated appraised value is:

Printed Name of Wrecker or Tow Company Representative

- Appraised Value:
1. Exceeds \$500.00
 2. Between \$200.00 and \$500.00
 3. Under \$200.00

Signature of Wrecker or Tow Company Representative

Printed Name of Authorized Representative

Remarks: _____

Signature of Authorized Representative Date

Control No.

DMV Office Address

VP-161 (Rev. 5/2010)

INSTRUCTIONS FOR COMPLETING RE-ASSIGNMENT OF JUNK CERTIFICATE

These instructions are valid for both versions of the Junk Certificate when completing an assignment.

1. Printed full legal name of buyer and address.
2. Signature of buyer and date.
3. Printed name of seller and address.
4. Signature of seller and date.

Front of Junk Certificate Revised 5-2011 and 5/2010

A Junk Certificate may only be issued to a licensed automobile wrecker or tow car operator for a vehicle that meets the definition of "Junk Vehicle" pursuant to NRS 487.260. This certificate authorizes an automobile wrecker to dismantle, scrap, crush or otherwise destroy the vehicle described on the face of this certificate. The identified vehicle may be sold to an automobile wrecker upon assignment of this certificate. The vehicle may never be rebuilt, titled or registered in Nevada again.

REASSIGNMENT

Printed Full Legal Name of Licensed Wrecker _____

Address _____
Address City State Zip Code

Signature of Licensed Wrecker _____ Date _____

Printed Name of Seller _____

Address _____
Address City State Zip Code

Signature of Seller _____ Date _____

SECOND REASSIGNMENT

Printed Full Legal Name of Licensed Wrecker _____

Address _____
Address City State Zip Code

Signature of Licensed Wrecker _____ Date _____

Printed Name of Seller _____

Address _____
Address City State Zip Code

Signature of Seller _____ Date _____

THIRD REASSIGNMENT

Printed Full Legal Name of Licensed Wrecker _____

Address _____
Address City State Zip Code

Signature of Licensed Wrecker _____ Date _____

Printed Name of Seller _____

Address _____
Address City State Zip Code

Signature of Seller _____ Date _____

Section III

Forms

Application for Salvage Title or Non-Repairable Vehicle Certificate Form VP-213

An Application for Salvage Title or Non-Repairable Vehicle Certificate (Form VP-213) must be submitted with properly endorsed ownership documents, including an odometer disclosure and applicable fees.

Within two days after receipt in the Department's Carson City office, the Department will issue a Salvage Title for the vehicle. The Salvage Title will be mailed to the new owner/purchaser as documented on the submitted title documents.

Before ownership interest in a salvage vehicle may be transferred, the Department must issue a Salvage Title. The titled owner or Insurance Company must forward the endorsed title with an Application for Salvage Title or Non-Repairable Vehicle Certificate to the Department within 30 days after the vehicle becomes a salvage vehicle.

A Duplicate Salvage Title may be issued by completing an Application for Salvage Title or Non-Repairable Vehicle Certificate, checking the transaction type box, indicating "Duplicate."

Requests for Salvage Titles or Non-Repairable Vehicle Certificates must be made through:

Attention: Salvage Unit
Department of Motor Vehicles
555 Wright Way
Carson City, NV 89711
(775) 684-4785
(775) 684-4493 (FAX)

INSTRUCTIONS FOR COMPLETING FORM VP-213

1. If the applicant is an Insurance Company, Licensed Nevada Business, Wrecker, or Recycler, they must complete the first section of the form.
 - a) Printed legal name of business.
 - b) Business license number or FEIN.
 - c) Telephone Number.
 - d) Current mailing address.
2. If the applicant is an individual owner, they must complete the second section of the form.
 - a) Printed full legal name.
 - b) Nevada Driver's license or Identification number.
 - c) Telephone number.
 - d) Current physical address.
 - e) Current mailing address.
3. The form must be signed by the registered owner or an authorized agent of the business.
4. Complete vehicle identification number, year and make.
5. Indicate if the vehicle is a Total Loss Insurance Settlement or a Flood-Damaged Vehicle.
6. Check the box if applying for a duplicate Salvage Title or Non-Repairable Vehicle Certificate.
7. Indicate if the vehicle is Salvage Only (not Total Loss or Flood Damaged). Salvage can only be requested by a licensed wrecker.
8. If applying for a Non-Repairable Vehicle certificate, check the box in front of the Non-Repairable Vehicle section.

Attach evidence of ownership to the application. Evidence of ownership must include a:

- Certificate of title/ownership;
- Salvage Title;
- Lien Sale Affidavit;
- Statement of Facts;
- Insurance Company Affidavit without Endorsed Title; or
- Court Order.

Ownership interest in a salvage vehicle may not be transferred unless the Department has issued a Salvage Title.



555 Wright Way
 Carson City, NV 89711-0700
 Reno/Sparks/Carson City (775) 684-4DMV (4368)
 Las Vegas area (702) 486-4DMV (4368)
 Rural Nevada or Out of State (877) 368-7828
www.dmvnv.com

APPLICATION FOR SALVAGE TITLE OR NON-REPAIRABLE CERTIFICATE
 NRS 487.480

PLEASE PRINT OR TYPE IN BLUE OR BLACK INK

1 Insurance Company, Licensed Nevada Business, Wrecker Or Recycler information:

Full Legal Name _____
 Nevada DMV Business License Number or FEIN _____
 Physical Nevada Address _____
Address City State Zip Code
 Mailing Address _____
Address City State Zip Code
 Telephone _____ E-mail _____

2 Individual information:

Full Legal Name _____
 Nevada Driver's License, ID Number, or DOB _____
 Physical Nevada Address _____
Address City State Zip Code
 Mailing Address _____
Address City State Zip Code
 Telephone _____ E-mail _____

3 Signature of Applicant _____ Date _____

The original, properly endorsed Certificate of Title, and/or other required documents, must be attached for the vehicle listed on this application.

4 Vehicle Identification Number

--	--	--	--	--	--	--	--	--	--	--	--	--	--	--	--	--	--	--	--

Year _____ Make _____ Model _____

5 Insurance Company or Individual Owner: Please check <input checked="" type="checkbox"/> appropriate box <input type="checkbox"/> Total Loss <input type="checkbox"/> Flood Damaged <small>In compliance with NRS 487.800</small>	Please check <input checked="" type="checkbox"/> if duplicate: <input type="checkbox"/> Duplicate	6 Licensed Wrecker Only: 7 <input type="checkbox"/> Salvage <small>In compliance with NRS 487.100</small>
--	---	--

8 **Non-Repairable Vehicle** (No fee required for Non-Repairable Vehicle certificate)
 NOTE: A Non-Repairable Vehicle may only be processed as parts or scrap metal by a licensed automobile wrecker, dismantler, or recycler. State law prohibits a Non-Repairable Vehicle from being rebuilt, reconstructed, or restored for operating on the highways of Nevada.

NOTE: Please include a \$10.00 Salvage Title fee for each Salvage Title requested. Licensed Nevada Automobile Wreckers are exempt from the Salvage Title fee.

VP-213 (Rev 12/2011)

Authorization for Vehicle Restoration Form VP-209

As required by NRS 487.480, the Department will not issue a Certificate of Registration or title for vehicles that have been issued a Salvage Title (if the vehicle is five years old or newer) unless the Department has authorized the restoration of the vehicle. Form VP-209, Authorization for Vehicle Restoration, must be completed.

The authorization to restore the vehicle must be obtained prior to the vehicle being rebuilt. Only an authorized Nevada Department of Motor Vehicles Representative may complete the form.

In order to register and/or title the vehicle, the Authorization for Vehicle Restoration, Salvage Title and Certificate of Inspection/Affidavit of Vehicle Construction for Rebuilt or Specially Constructed Vehicles (VP-64) must be provided. Additional documents may be required as deemed necessary by the Department.

Instructions for Completing Authorization for Vehicle Restoration

1. **Vehicle Description:** The description must include the vehicle identification number, year, make, type, model, and odometer reading.
2. **Owner Information:** The name and address appearing in section 2 must be the person in possession of the vehicle at the time of inspection.
 - a) Printed full legal name.
 - b) Nevada Driver's license, Identification Card Number or Date of Birth
 - c) Current physical address.
 - d) Current mailing address.
3. **Authorized Signature:** The DMV representative who inspects the vehicle must sign and date the form to validate it.

14. Enter the Buyer's telephone number.
15. Enter the Buyer's email address.
16. Enter the vehicle information, including the vehicle identification number (VIN), year, make and model.
17. Check if the vehicle has been rebuilt as the term is defined in NRS 482.098.
18. If a lien exists, record the name of the lienholder. If no liens exist, write "NONE."
19. Enter Nevada Driver's License, Identification Card Number, or FEIN for businesses:
20. Enter the mailing address for the lienholder.
21. Enter the seller's full legal name.
22. Enter Nevada Driver's License, Identification Card Number, or FEIN for businesses:
23. Enter the seller's mailing address.
24. Enter this Seller's Signature; must be included.
25. Enter the Date the Seller signed the Bill of Sale form.

Note: Any alteration or erasure on the Bill of Sale requires additional verification.



555 WRIGHT W
CARSON CITY, NV 89711-07
Reno/Sparks/Carson City (775) 684-4DMV (43)
Las Vegas Area (702) 486-4DMV (43)
Rural Nevada or Out of State (877) 368-7
www.dmvnv.gov

BILL OF SALE

NRS 482.426

A Bill of Sale releases interest in a vehicle. A Certificate of Title or other ownership documents must accompany this form.

INSTRUCTIONS

- All areas must be completed in full.
Complete the buyer area exactly as the new Certificate of Title will be printed.
Any alterations or erasures will require additional documentation and/or verification.

Please print or type

Know all men by these presents

That in consideration of (1) Dollars (2) (\$) and other value consideration, the receipt whereof is hereby acknowledged, the undersigned (seller) does hereby sell, transfer and deliver unto:

New Owner information (If more than two owners, complete and attach an additional Bill of Sale (VP104) form; indicate "AND" or "OR" between second and third owners)

Full Legal Name of 1st Buyer (3) (4) and (5) or

Nevada Driver's License, Identification Card Number, Date of Birth, or FEIN (5) for businesses

Physical Address (6) Address City State Zip Code

Mailing Address (7) Address City State Zip Code

Full Legal Name of 2nd Buyer (8)

Nevada Driver's License, Identification Card Number, Date of Birth, or FEIN (9) for businesses

Physical Address (10) Address City State Zip Code

Mailing Address (11) Address City State Zip Code

Buyer's Signature (12) Date (13)

Telephone (14) E-mail (15)

his right, title and interest in and to the following described vehicle:

(16) Vehicle Identification Number grid

Year Make Model

(17) This vehicle has been Rebuilt as the term is defined in NRS 482.098

Buyer certifies Lien in favor of (18)

Nevada Driver's License, Identification Card Number, Date of Birth, or FEIN (19) for businesses

Address (20) Address City State Zip Code

Seller certifies that he is the lawful owner of said vehicle; that he has the right to sell the aforesaid; and that he will warrant and defend the title of same against the claims and demands of all persons whomsoever except lienholder noted above.

Seller's Full Legal Name (21)

Nevada Driver's License, Identification Card Number, Date of Birth, or FEIN for businesses (22)

Mailing Address (23) Address City State Zip Code

Signature of Seller (24) Date (25)

VP104 (Rev. 8-2011)

**CERTIFICATE OF INSPECTION / AFFIDAVIT OF VEHICLE
CONSTRUCTION**
Form VP-64

**CERTIFICATE OF INSPECTION / AFFIDAVIT OF MOTORCYCLE /
TRIMOBILE CONSTRUCTION**
Form VP-64M

**CERTIFICATE OF INSPECTION AND AFFIDAVIT OF TRAILER
CONSTRUCTION Form VP-223**

NRS 484.110 and 487.800

Certificate of Inspection / Affidavit of Vehicle Construction (Form VP-64), Certificate of Inspection / Affidavit of Motorcycle / Trimobile Construction (Form VP-64M) or Certificate of Inspection Affidavit of Trailer Construction (Form VP-223) must be completed in order to register or title a vehicle for which a Salvage Title has been issued. The Certificate of Title and other documentation, as required, must also accompany the VP-64, VP-64M or VP-223.

An owner or authorized employee of a Nevada registered garageman, licensed body shop, or rebuilder must certify that a salvage vehicle or motorcycle is repaired or rebuilt and must comply with the standards published and commonly applied in the motor vehicle repair industry.

Motorcycle repair shops must be registered with the Department.

If any safety equipment that was present in a motor vehicle at the time it was manufactured is repaired or replaced, the equipment must be repaired or replaced to the standards published and commonly applied in the motor vehicle repair industry.

If a motor vehicle has been in an accident and a garageman, operator of a body shop, or rebuilder accepts or assumes control of the motor vehicle to make any repair, the garageman or operator shall:

- a) For a motor vehicle that is equipped with an airbag that has been deployed, replace the airbag in a manner that complies with the standards set forth in 49 C.F.R. § 571.208, Standard No. 208, for such equipment; and
- b) For a motor vehicle that is equipped with a seatbelt assembly which requires repair or replacement, repair or replace the seatbelt assembly in a manner that complies with the standards set forth in 49 C.F.R. § 571.209, Standard No. 209, for such equipment.

A garageman or operator of a body shop who is licensed pursuant to the provisions of chapter 487 of NRS and who performs the work required must retain a written record of the work, including, without limitation, the date of the repair, rebuilding or replacement, and any identifying information regarding any parts or equipment used in the repair, rebuilding or replacement.

Nevada Highway Patrol Troopers, local police and sheriffs are considered authorized agents of the Department and may complete a VIN inspection (VP-15). However an Authorized DMV Agency Inspector must complete Forms VP-64 and Form VP-64M. An "Authorized Nevada DMV Representative" must complete the VP-223 and VP-209. The agency name and badge number must be recorded on the form.

Nevada Certificates of Title issued for vehicles using Form VP-64, VP-64M or VP-223 will be branded in accordance with statements made on the form by the owner.

Form VP-64, VP-64M or VP-223 may also be used for required mechanic's inspections, and required Department safety checks.

Certificate of Inspection / Affidavit of Vehicle Construction Instruction for Completing Form VP-64

1. Indicate whether the vehicle is rebuilt salvage, reconstructed, specially constructed or a manufactured kit.

PART I – Safety Inspection – To be completed by a Nevada registered garage, licensed Nevada body shop or rebuilder.

2. Enter vehicle description must be completed in full including the year, make, model, type and vehicle identification number (VIN).
3. If items being inspected are acceptable, the applicable box must be checked after each item is inspected. Unless the item is not applicable (N/A), if an item being inspected is marked as “fail” or not marked the vehicle cannot be registered until repairs are made.
4. Enter printed name and DMV business license number of the business completing the form.
5. Enter address, city, state, and zip code of the business completing the form.
6. Enter full legal name of the person completing the form.
7. Signature and position of person completing the form.
8. Enter date the inspection was completed.

PART II – Affidavit of Construction for Rebuilt Salvage, Reconstructed, and Specially Constructed Vehicles: to be completed by the person who owns the vehicle.

9. Check appropriate box for how the vehicle was constructed.
10. Enter vehicle information; year, make, model, type, and number of axles.
11. Enter affiant’s printed full legal name as it appears on their Nevada Driver’s license or Identification card.
12. Enter affiant’s driver’s license or identification card number.
13. Enter affiant’s telephone number.
14. Enter affiant’s current physical address.
15. Enter affiant’s current mailing address.
16. Affiant’s signature.
17. Enter date Part II was completed.
18. Affiant’ signature must be witnessed by Authorized Nevada DMV Representative or Notary Public.

PART III – To be completed by an Authorized Nevada DMV Agency Representative.

19. VIN and part description must be completed for all components used.
20. Verify VIN from Part I.
21. Check box for VIN inspection fee.
22. Fill in if VIN was assigned or VIN from manufacturer’s kit.
23. Check box if VIN was assigned.
24. List the vehicle information if it is different than listed in Part I.

25. Reason VIN assigned, if applicable.
26. Complete the odometer statement.
27. If the vehicle was restored prior to authorization, this box can be checked authorizing restoration after the fact.
28. Additional comments, if applicable.
29. Printed Name and Signature of Authorized Nevada DMV Representative - Include Employee Identification Number.
30. Date Part III was completed.



555 WRIGHT WAY
CARSON CITY, NV 89711-3700
Reno/Sparks/Carson City (775) 684-4DMV (4368)
Las Vegas Area (702) 486-4DMV (4368)
Rural Nevada or Out of State (877) 368-7828
www.dmvnv.com

CERTIFICATE OF INSPECTION / AFFIDAVIT OF VEHICLE CONSTRUCTION NRS 482.223

(1) [] Rebuilt/Salvage [] Reconstructed [] Specially Constructed [] Manufactured Kit

A VEHICLE LABELED FOR "OFF-ROAD USE ONLY" MAY NOT BE CONVERTED FOR ON-ROAD USE WITH THE EXCEPTION OF AN OFF HIGHWAY TWO-WHEELED MOTORCYCLE (REFERENCE FORM VP-254).

Instructions

- All parts of this form must be completed.
A Nevada Registered Garage, Licensed Nevada Body Shop or Rebuilder must complete Part I.
The vehicle owner must complete Part II and verify with a Nevada DMV Agency Representative or Notary Public.
A Nevada DMV Agency Representative must complete Part III.
A vehicle intended for "on-road" use by the manufacturer will be labeled stating FMVSS and EPA standards have been met.
All inspection items must be checked "PASS," indicating the item is in a safe operating condition before this vehicle can be registered and/or titled.
This form is not used for conversions. Reference Form VP-254 for an Off-Highway Two Wheeled Motorcycle Conversion Form.
OWNERSHIP DOCUMENTS MUST ACCOMPANY THIS FORM

Important: A new form and inspection must be completed if any inspection items are marked fail, not marked, improperly marked, or if corrections were made to the form.

PART I SAFETY INSPECTION

Must be completed by a Nevada Registered Garage, Licensed Nevada Body Shop or Rebuilder
The work performed on the vehicle must meet the standards of the manufacturer for mechanical fitness and safe

(2) Year _____ Make _____ Model _____ Type _____

Vehicle Identification Number (VIN)

Grid for VIN entry with 17 columns and 1 row.

Important: Adding the equipment listed below will not qualify a vehicle labeled by the manufacturer for OFF-ROAD USE ONLY, to be registered for on-road use

(3) Check (v) Appropriate Boxes:

Table with columns for PASS, FAIL, N/A for items: Windshield, Side Glass, Rear Glass, Mirrors, Steering, Air Bags, Frame, Headlights, Taillights, Turn Signals, Parking Lights, Brakes, Horn, Muffler, Mudguards (over 26,000 lbs), Windshield Wipers, Emergency Brake, Safety Belts, Shoulder Harness.

Other (explain) _____
Before signing below all items above must be marked "pass" indicating the items are in a safe operating condition. N/A may apply to air bags, mudguards, reflectors and safety belts/shoulder harness only if the item was not original equipment. N/A may apply to glass and windshield not present; if present it must be proper safety glass.

Please Print or Type

(4) Legal Business Name _____ Name _____ DMV Business License or Registration Number _____

(5) Address _____ City _____ State _____ Zip Code _____

By signing this document, I certify the described motor vehicle is mechanically safe to operate and is equipped with required devices necessary for safe operation upon the highway. I further certify that if repaired, the passenger restraint devices (as applicable), to include seat belts and/or airbags, were repaired pursuant to Title 49 CFR 571.209, Standard 20 and Title 49 CFR 571.208, Standard 208, respectively, and have been satisfactorily repaired to the applicable standards the manufacturer and the motor vehicle repair industry.

(6) _____ (7) _____ (8) _____
Printed Full Legal Name of Affiant Signature and Position Date

PART II AFFIDAVIT OF CONSTRUCTION FOR REBUILT SALVAGE, RECONSTRUCTED AND SPECIALLY CONSTRUCTED VEHICLES

The undersigned, being duly sworn upon oath, deposes and says they are the owner of the vehicle listed below. It vehicle was rebuilt or built from parts and materials on hand, or parts and materials purchased from a supplier, or manufactured kit purchased from a supplier, or purchased "as is" from a rebuilder, or otherwise lawfully acquired. The affiant or registered owner makes this affidavit as part of an application to the Nevada Department of Motor Vehicles for Certificate of Registration and/or a Certificate of Title. The undersigned will indemnify and hold harmless the State Nevada on account of the issuance of a Certificate of Registration and/or Certificate of Title for said vehicle.

- (9) Vehicle was constructed from parts/material on hand Vehicle was assembled from manufactured kit
- Vehicle was built from purchased parts/material, receipts attached Vehicle was purchased "as is" from rebuilder

Please Print or Type
 (10) Year _____ Make (if a manufactured kit) _____ Model _____ Type _____ No. of axles _____

(11) Affiant's Full Legal Name _____
 (As appears on Drivers License or ID) First _____ Middle _____ Last _____

(12) Drivers License, ID Number, or DOB _____ (13) Telephone Number _____

(14) Affiant's Physical Address _____
 City _____ State _____ Zip Code _____

(15) Affiant's Mailing Address _____
 City _____ State _____ Zip Code _____

(16) Affiant's Signature _____ (17) Date _____

(18) _____
 Printed name of Nevada DMV Agency Representative Or Notary Public Signature of Nevada DMV Agency Representative Or Notary Public ID No. Date

PART III COMPLETED BY AN AUTHORIZED NEVADA DMV REPRESENTATIVE

Note: Attach copies of any title or purchase documents, supplied by owner, showing information of components used from other vehicles.

(19) VIN & Part _____ VIN & Part _____
 VIN & Part _____ VIN & Part _____

(20) VIN indicated in Part I Verified

--	--	--	--	--	--	--	--	--	--	--	--	--	--	--	--	--	--	--	--	--	--	--	--	--	--

(21) Vehicle Inspection Fee

(22) DMV Assigned VIN or Kit Manufacturer's VIN

--	--	--	--	--	--	--	--	--	--	--	--	--	--	--	--	--	--	--	--	--	--	--	--	--	--

VIN Assignment Fee

(23) Different than listed in Part I Year (24) _____ Make _____ Model _____ Type _____

Reason VIN assigned (25) _____

Odometer Reading (as shown on apparatus) (26)

--	--	--	--	--	--

 NO TENTHS

- If the vehicle's odometer apparatus only displays five numbers, please put an X in the first box.
- 1. The mileage stated is in excess of its mechanical limits.
 - 2. The odometer reading is not the actual mileage. WARNING - ODOMETER DISCREPANCY
 - 3. Exempt - Model year over 9 years old.

(27) This vehicle was restored prior to authorization. The undersigned is authorizing restoration after the fact on this form in lieu of form VP-209.

(28) Additional comments: _____

(29) _____ (30) _____
 Printed Name of Nevada DMV Agency Representative Signature of Nevada DMV Agency Representative ID NO. Date

**Certificate of Inspection / Affidavit of Motorcycle / Trimobile
Construction
Instruction for Completing Form VP64M**

1. Indicate whether the motorcycle or trimobile is rebuilt, reconstructed, specially constructed or a manufactured kit.

PART I – SAFETY INSPECTION – To be completed by a Nevada registered garage, licensed motorcycle repair shop, licensed Nevada body shop or rebuilder.

2. Enter motorcycle or trimobile description must be completed in full including the year, make, model, type and vehicle identification number (VIN).
3. If items being inspected are acceptable, the applicable box must be checked after each item is inspected. Unless the item is not applicable (N/A), if an item being inspected is marked “fail” the vehicle cannot be registered until repairs are made.
4. Enter printed name and DMV business license number of the business completing the form.
5. Enter address, city, state, and zip code of the business completing the form.
6. Enter full legal name of person completing the form.
7. Signature and position of person completing the form.
8. Enter date the inspection was completed.

PART II – Affidavit of Construction for Rebuilt Salvage, Reconstructed or Specially Constructed Motorcycle / Trimobile. To be completed by the person who owns the motorcycle or trimobile.

9. Check appropriate box for how the vehicle was constructed.
10. Enter vehicle information; year, make, model, type, and number of axles.
11. Enter affiant’s printed full legal name as it appears on their Nevada Driver’s license or Identification card.
12. Enter affiant’s driver’s license or identification card number.
13. Enter affiant’s telephone number.
14. Enter affiant’s current physical address.
15. Enter affiant’s current mailing address.
16. Affiant’s signature.
17. Affiant’s signature must be witness by Authorized Nevada DMV Representative or Notary Public.
18. Enter date Part II was completed.

PART III – Completed by an Authorized Nevada DMV Representative.

19. VIN and part description must be completed for all components used.
20. Verify VIN from Part I.
21. Check box for Vehicle Inspection Fee.
22. Fill in if VIN was assigned or VIN from manufacturer’s kit.
23. Check box for VIN inspection fee.

24. Check box if VIN is different from Part I
25. List the vehicle information if it is different than listed in Part I.
26. If a VIN was assigned, list the reason.
27. Complete the odometer statement.
28. If the vehicle was restored prior authorization, this box can be checked authorizing restoration after the fact.
29. Check if the motorcycle is labeled for off-road use.
30. Additional comments, if necessary.
31. Printed Name and Signature of Authorized Nevada DMV Representative. Include Employee Identification Number.
32. Date Part III was completed.



555 WRIGHT WAY
CARSON CITY, NV 89711-0700
Reno/Sparks/Carson City (775) 684-4DMV (4368)
Las Vegas Area (702) 496-4DMV (4368)
Rural Nevada or Out of State (877) 368-7828
www.dmvnv.com

CERTIFICATE OF INSPECTION / AFFIDAVIT OF MOTORCYCLE/TRIMOBILE CONSTRUCTION
NRS 482.223

(1) [] Rebuilt Salvage [] Reconstructed [] Specially Constructed [] Manufactured Kit

THIS FORM IS NOT INTENDED FOR USE AS AN OFF-HIGHWAY TWO WHEELED MOTORCYCLE CONVERSION FORM. USE FORM VP-254 FOR MOTORCYCLE CONVERSIONS.

Instructions

- All parts of this form must be completed.
A Nevada Registered Garage, Motorcycle Repair Shop, Licensed Nevada Body Shop or Rebuilder must complete Part I.
The vehicle owner must complete Part II and verify with a Nevada DMV Agency Representative or Notary Public.
A Nevada DMV Agency Representative must complete Part III.
A motorcycle intended for "on-road use" by the manufacturer will have a label or labels attached stating FMVSS and EPA standards have been met.
All inspection items must be checked "PASS," indicating the item is in a safe operating condition before this motorcycle can be registered and/or titled.
OWNERSHIP DOCUMENTS MUST ACCOMPANY THIS FORM

Important: A new form and inspection must be completed if any inspection items are marked fail, not marked, improperly marked, or if corrections were made to the form.

PART I SAFETY INSPECTION

Must be completed by a Nevada Registered Garage, Licensed Motorcycle Repair Shop, Licensed Nevada Body Shop or Rebuilder

The work performed on the vehicle must meet the standards of the manufacturer for mechanical fitness and safety

(2) Year _____ Make _____ Model _____ Type _____

Vehicle Identification Number (VIN)

Grid for VIN entry: 12 columns, 1 row

Important: This is not a conversion form. Reference Form VP-254 for motorcycle conversion information.

(3) Check (v) Appropriate Boxes

N/A (Turn Signals) is only for motorcycles built prior to January 1, 1973, not originally equipped with turn signals.

Table with columns for PASS, FAIL, N/A and rows for Horn, Headlight(s), Turn Signals, Frame, Reflectors, Taillight, Muffler(s), DOT Legal Tires, Brake Light, Fenders, Mirrors, Brakes.

Before signing below all items above must be marked "pass" indicating the items are installed per NRS and in a safe operating condition.

Please Print or Type

(4) Legal Business Name _____ Name _____ DMV Business License or Registration Number _____

(5) Address _____ City _____ State _____ Zip Code _____

By signing this document, I certify the described motorcycle is mechanically safe to operate and is equipped with all required devices necessary for safe operation upon the highway. I further certify that if repaired, all safety devices have been satisfactorily repaired to the applicable standards of the manufacturer and the motor vehicle repair industry.

(6) _____ Printed Full Legal Name of Affiant (7) _____ Signature and Position (8) _____ Date

PART II AFFIDAVIT OF CONSTRUCTION FOR REBUILT SALVAGE, RECONSTRUCTED, OR SPECIALLY CONSTRUCTED MOTORCYCLE

The undersigned, being duly sworn upon oath, deposes and says they are the owner of the motorcycle listed below. The motorcycle was rebuilt or built from parts and materials on hand, or parts and materials purchased from a supplier, or manufactured kit purchased from a supplier, or purchased "as is" from a rebuilder, or otherwise lawfully acquired. The affiant or registered owner makes this affidavit as part of an application to the Nevada Department of Motor Vehicles for Certificate of Registration and/or a Certificate of Title. The undersigned will indemnify and hold harmless the State of Nevada on account of the issuance of a Certificate of Registration and/or Certificate of Title for said motorcycle.

- (9) Motorcycle was constructed from parts/material on hand Motorcycle was assembled from manufactured kit
- Motorcycle was built from purchased parts/material, receipts attached Motorcycle was purchased "as is" from rebuilder

Please Print or Type

(10) _____
Year Make (if a manufactured kit) Model Type No. of axles

(11) Affiant's Full Legal Name _____
(As appears on Drivers License or ID) First Middle Last

(12) Drivers License, ID Number, or DOB _____ Telephone Number (13) _____

(14) Affiant's Physical Address _____

(15) Affiant's Mailing Address _____ City State Zip Code

(16) Affiant's Signature _____ City State Zip Code Date

(17) _____ (18) _____
Printed name of Nevada DMV Agency Representative Signature of Nevada DMV Agency Representative ID No. Date
 Or Notary Public Or Notary Public

PART III COMPLETED BY AN AUTHORIZED NEVADA DMV REPRESENTATIVE

Note: Attach copies of any title or purchase documents, supplied by owner, showing information of components used from other vehicles.

(19) VIN & Part _____ VIN & Part _____

VIN & Part _____ VIN & Part _____

(20) VIN indicated in Part I Verified _____ (21) Vehicle Inspection Fee

--	--	--	--	--	--	--	--	--	--	--	--	--	--	--	--	--	--	--	--

(22) DMV Assigned VIN _____ (23) VIN Assignment Fee

--	--	--	--	--	--	--	--	--	--	--	--	--	--	--	--	--	--	--	--

(24) Different than listed in Part I Year (25) _____ Make _____ Model _____
 Type _____

Reason VIN assigned (26) _____

Odometer Reading (as shown on apparatus)

(27)					
------	--	--	--	--	--

NO TENTHS

- If the vehicle's odometer apparatus only displays five numbers, please put an X in the first box.
- 1. The mileage stated is in excess of its mechanical limits.
 - 2. The odometer reading is not the actual mileage. WARNING – ODOMETER DISCREPANCY
 - 3. Exempt – Model year over 9 years old.

(28) This vehicle was restored prior to authorization. The undersigned is authorizing restoration after the fact on this form in lieu of form VP-209.

(29) This motorcycle is labeled by the manufacturer for on-road use.

(30) Additional comments: _____

(31) _____ (32) _____
Printed Name of Nevada DMV Agency Representative Signature of Nevada DMV Agency Representative ID NO. Date

VP-64M (Rev. 8/2011)

Certificate of Inspection and Affidavit of Trailer Construction Instructions for Completing Form VP-223

1. Indicate whether the trailer is rebuilt, reconstructed, specially constructed, or a manufactured kit.

PART 1 – INSPECTION – To be completed by an authorized Nevada Department of Motor Vehicles Representative.

2. Enter trailer's empty weight.
3. Enter trailer's overall width.
4. If items being inspected are acceptable, check the applicable box after each item is inspected. Unless the time is not applicable (N/A), if an item being inspected is marked "fail" the vehicle cannot be registered until repairs are made.
5. Enter Vehicle Identification Number (VIN).
6. Check if a VIN was assigned.
7. Enter year, make model, type and number of axles on the trailer.
8. Check the appropriate box with regard to the trailer including living quarters.
9. Enter reason VIN was assigned.
10. Enter additional comments, if necessary.
11. Printed Name of Authorized Nevada DMV Representative. The authorized Nevada DMV Representative should sign the form and include their employee identification number.
12. Enter date Part 1 was completed.

PART 2 – AFFIDAVIT OF TRAILER CONSTRUCTION – To be completed by the person who built or rebuilt the trailer, if available, or the owner.

13. Check appropriate box for how the trailer was constructed.
14. Enter affiant's printed full legal name as it appears on their Nevada Driver's license or Identification card.
15. Enter affiant's Driver's license or Identification card number.
16. Enter affiant's current physical address.
17. Enter affiant's current mailing address.
18. Enter affiant's Driver's license or Identification card number.
19. Enter affiant's telephone number.
20. Affiant's signature.
21. Enter date affiant signed form.
22. Affiant's signature must be witnessed by a Notary Public or Authorized Nevada DMV Representative.
23. The figures can be used to detail any necessary repairs.

PART 2 – AFFIDAVIT OF TRAILER CONSTRUCTION

To be completed by trailer owner

The undersigned, being duly sworn upon oath, deposes and says they are the owner of the trailer described in Part 1 of this form. This trailer was built from parts and materials on hand, purchased materials from a supplier, a manufactured kit, "as is" from a builder, or otherwise lawfully acquired. The affiant or registered owner makes this affidavit as part of an application to the Nevada Department of Motor Vehicles for a Certificate of Registration and/or a Certificate of Title. The undersigned will indemnify and save harmless the State of Nevada on account of the issuance of a Certificate of Registration and/or Certificate of Title for said trailer.

- 13 Trailer was built from materials on hand Trailer built from purchased materials, (receipts attached)
 Trailer was purchased "as is" from builder Trailer was assembled from a manufactured kit

14 Affiant's Full Legal Name _____

15 Nevada Driver's License, Identification Card Number, or Date of Birth _____

16 Physical Address _____
 City State Zip Code

17 Mailing Address _____
 City State Zip Code

18 NV Driver's License or ID Number _____ Phone Number (____) **19**

20 Affiant's Legal Signature _____ Date **21**

22 SUBSCRIBED AND SWORN to before me this _____ day of _____, 20_____.

 Notary Public or Authorized Nevada DMV Representative

23

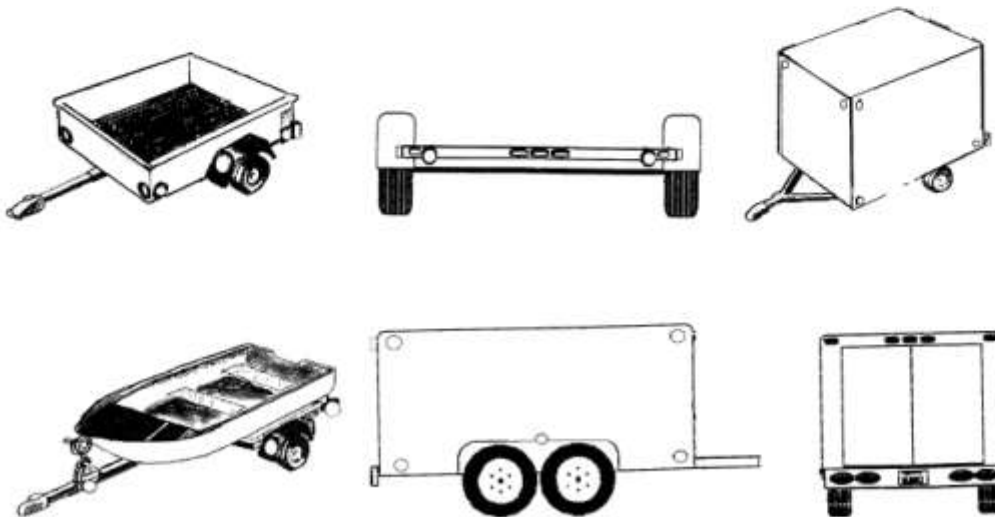

VP 223 (Revised 10/2011)

Certificate of Inspection for Rebuilt Vehicles – (No Salvage)
Form VP-64A
NRS 482.098, 482.220 & 482.223

Certificate of Inspection for Rebuilt Vehicles – Not Salvage (Form VP-64A) must be completed in order to register or title a vehicle for which has had one or more major components replaced. Major components are cowl assembly, rear clip assembly, roof assembly, floor pan assembly, conventional frame coupled with one additional major component, or complete front inner structure for a unibody. The term “rebuilt” does not include a vehicle for which the only change is the installation of a truck cab assembly. Form VP-64A must also be accompanied by the Certificate of Title and other documentation, as required.

An owner or authorized employee of a Nevada registered garage, licensed body shop, or rebuilder must certify that a rebuilt vehicle is repaired and must comply with the standards published and commonly applied in the motor vehicle repair industry.

If any safety equipment that was present in a motor vehicle at the time it was manufactured is repaired or replaced, the equipment must be repaired or replaced to the standards published and commonly applied in the motor vehicle repair industry.

An Authorized DMV Agency Inspector must complete Part III of Form VP-64A.

Nevada Certificates of Title issued for vehicles using Form VP-64A will be branded in accordance with statements made on the form by the owner.

Instructions for completing form VP-64A

PART I – INSPECTION Must be completed by a Nevada registered garaged, licensed Nevada body shop or rebuilder.

1. Enter year, make, model and type of vehicle.
2. Enter vehicle identification number (VIN).
3. Check the appropriated box or boxes of the major components replaced.
4. Enter the business name and license number, as it is registered with the DMV, completing the inspection.
5. Enter the current address of the business.
6. Print full legal name of Affiant.
7. Signature and position of Affiant.
8. Enter date inspection was completed.

PART II – AFFIDAVIT OF CONSTRUCTION FOR A REBUILT MOTOR VEHICLE To be completed by the owner of the rebuilt vehicle.

9. Check appropriate box for how the vehicle was rebuilt.
10. Enter the year, make, model, type and number of axles of the vehicle.

11. Enter Affiant's printed full legal name as it appears on the Nevada driver's license or Nevada identification card.
12. Enter Affiant's Nevada driver's license or identification number.
13. Enter Affiant's telephone number.
14. Enter the Affiant's current physical address.
15. Enter the Affiant's current mailing address.
16. Enter the Affiant's signature.
17. Signature must be witnessed by an Authorized Nevada DMV Representative or notary.
18. Enter the date the form was signed.

PART III To be completed by a Nevada DMV agency representative.

19. VIN and part description must be completed for all components used.
20. Verify VIN from Part I.
21. Check box for VIN inspection fee.
22. Fill in if VIN was assigned by the DMV.
23. Check box if VIN was assigned.
24. List the vehicle information if it is different than listed in Part I.
25. If a VIN was assigned, list the reason.
26. Complete the odometer statement.
27. Additional comments, if necessary.
28. Printed Name and Signature of Authorized Nevada DMV Agency Representative.
Include Employee Identification Number.
29. Date Part III was completed.



555 WRIGHT WAY
 CARSON CITY, NV 89711-0700
 Reno/Sparks/Carson City (775) 684-4DMV (4368)
 Las Vegas Area (702) 486-4DMV (4368)
 Rural Nevada or Out of State (877) 368-7628
www.dmvnv.com

CERTIFICATE OF INSPECTION FOR REBUILT VEHICLES (NOT SALVAGE)

NRS 482.098, NRS 482.220 & NRS 482.223

OWNERSHIP DOCUMENTS MUST ACCOMPANY THIS FORM FOR THE DEPARTMENT TO TITLE OR REGISTER.

Instructions

- All parts of this form must be completed.
- Part I must be completed by a Nevada Registered Garage, Licensed Nevada Body Shop or Rebuilder.
- Part II must be completed by the vehicle owner and verify with a Nevada DMV Agency Representative or Notary Public.
- Part III must be completed by a Nevada DMV Agency Representative.

Important: Corrections on this form will not be accepted. – If a mistake is made, you must complete a new form.

PART I Safety Inspection

Must be completed by a Nevada Registered Garage, Licensed Nevada Body Shop, or Rebuilder

(1) Year _____ Make _____ Model _____ Type _____

(2) Vehicle Identification Number (VIN)

--	--	--	--	--	--	--	--	--	--	--	--	--	--	--	--	--	--	--

- (3) Check (✓) the Appropriate Box(es) to indicate components replaced.
- Cowl Rear clip Roof assembly Floor pan assembly
 Complete front inner structure of a unibody Conventional frame & one major component

NOTE: In addition to all other disclosures, by signing Part I below the affiant attests that the item(s) checked have been installed to the applicable standards of the manufacturer and the automotive repair industry and are in a safe operating condition.

Please Print or Type

(4) Legal Business Name _____ Name _____ DMV Business License or Registration Number _____

(5) Address _____ City _____ State _____ Zip Code _____

By signing this document, I certify the described vehicle is mechanically safe to operate. I further certify the items indicated have been satisfactorily repaired to the applicable standards of the manufacturer and the motor vehicle repair industry. In addition, I certify any safety equipment including occupant restraint devices, which were present in the vehicle at the time the vehicle was manufactured are present and operational to the standards of the manufacturer.

(6) _____ (7) _____ (8) _____
 Printed Full Legal Name of Affiant Signature and Position Date

PART II AFFIDAVIT OF CONSTRUCTION FOR A REBUILT MOTOR VEHICLE

The undersigned, being duly sworn upon oath, deposes and says they are the owner of the vehicle described on this document. This vehicle was rebuilt from parts and materials on hand, or parts and materials purchased from a supplier, or otherwise lawfully acquired. The affiant or registered owner makes this affidavit as part of an application to the Nevada Department of Motor Vehicles for a Certificate of Registration and/or a Certificate of Title. The undersigned will indemnify and hold harmless the State of Nevada on account of the issuance of a Certificate of Registration and/or Certificate of Title for said vehicle.

- (9) Vehicle was rebuilt from parts/material on hand Vehicle was rebuilt from purchased parts/material, receipts attached

(10) Year _____ Make _____ Model _____ Type _____ No. of axles _____

Please Print or Type

(11) Affiant's Full Legal Name _____
 (As appears on Drivers License) First Middle Last

(12) NV Driver's License, ID Number, or DOB _____ (13) Telephone Number (_____) _____

(14) Affiant's Physical Address _____ City _____ State _____ Zip Code _____

(15) Affiant's Mailing Address _____ City _____ State _____ Zip Code _____

(16) Affiant's Signature _____ Date _____

(17) _____ (18) _____
 Printed name of Nevada DMV Agency Representative Signature of Nevada DMV Agency Representative ID No. Date
 Or Notary Public Or Notary Public

MD-66A (6.7011)

PART III Completed by a Nevada DMV Agency Representative

Note: Attach copies of any title or purchase documents showing information of components used from other vehicles.

(19) VIN & Part _____ VIN & Part _____

VIN & Part _____ VIN & Part _____

(20) VIN indicated in Part I Verified

--	--	--	--	--	--	--	--	--	--	--	--	--	--	--	--	--	--	--	--	--	--

(21) Vehicle Inspection Fee

(22) DMV Assigned VIN

--	--	--	--	--	--	--	--	--	--	--	--	--	--	--	--	--	--	--	--	--	--

(23) VIN Assignment Fee

(24) Different than listed in Part I Year _____ Make _____ Model _____ Type _____

(25) Reason VIN assigned _____

Odometer Reading (as shown on apparatus)
NO TENTHS

(26)							
------	--	--	--	--	--	--	--

If the vehicle's odometer apparatus only displays five numbers, please put an X in the first box.

- 1. The mileage stated is in excess of its mechanical limits.
- 2. The odometer reading is not the actual mileage. WARNING – ODOMETER DISCREPANCY
- 3. Exempt – Model year over 9 years old.

(27) Additional comments: _____

(28) _____ (29) _____
 Printed name of Nevada DMV Agency Representative Signature of Nevada DMV Agency Representative ID NO. Date

"Rebuilt vehicle" (NRS 482.098) means:

1. A vehicle for which one or more of the following major components have been replaced:
 - (a) Cowl assembly;
 - (b) Rear clip assembly;
 - (c) Roof assembly;
 - (d) Floor pan assembly;
 - (e) Conventional frame coupled with one additional major component; or
 - (f) Complete front inner structure for a unibody.

Note: The term "rebuilt" does not include a vehicle for which the only change is the installation of a truck cab assembly.

Definitions

- "Complete front inner structure for a unibody" (NRS 482.0154) means the weld on structure of a vehicle, including, without limitation, the radiator support. Left and right aprons, upper and lower rails and strut towers, designed and intended to be located forward of the cowl assembly.
- "Conventional frame" (NRS 482.0157) means the main longitudinal structural members of the chassis of a vehicle used as the major support in the construction of the vehicle.
- "Cowl assembly" (NRS 482.018) to mean the forward structural portion of a vehicle to which are intended to be attached all or a part of the windshield frame, fire wall, housing of the instrument panel and hinges for the front doors.
- "Floor pan assembly" (NRS 482.0385) means the pans designed and intended to form the floor of the passenger compartment of a vehicle.
- "Rear clip assembly" (NRS 482.0965) means the entire rear structural portion of a vehicle designed and intended to be located behind the rear seat of the vehicle.
- "Roof assembly" (NRS 482.106) means the structural parts of a vehicle, including, without limitation, more than one-half of the vertical roof supports, the framework of the roof and the exterior metal skin that together are designed and intended to be located over the passenger compartment to form the roof of the vehicle.

Erasure Affidavit Form VP-19

An Erasure Affidavit (VP-19) must be completed whenever an error has been made on Certificate of Title documents. The affidavit provides for the removal of incorrect information.

An Erasure Affidavit cannot be used to correct anything having to do with signatures, vehicle information, or the mileage disclosure.

An individual taking full responsibility for an error, change, or removal of information on ownership documents must complete and sign the Erasure Affidavit. If a person is being removed from the ownership documents, that individual is required to sign the affidavit. When representing a business, the business name and the name of the authorized business representative must appear on the affidavit.

When correcting information, draw a single line through the error and write the corrected information above. Do not obliterate the information. If the correct information cannot be placed in the appropriate area on the Certificate of Title, Manufacturer's Certificate of Origin or Salvage Title, it may be placed on the Erasure Affidavit.

Instructions for Completing the Erasure Affidavit

1. Enter complete description of the vehicle, including year, make, model, and vehicle identification number (VIN) of the vehicle. The description of the vehicle must match all corresponding documents.
2. Enter a complete description of the reason for the change or removal of information on the title documents.
3. Enter Affiant's printed full legal name as it appears on the Nevada driver's license or Nevada identification card.
 - If the person is representing a business, the business name and the name of the representative must also appear (i.e., ABC Auto Sales, by Sam Jones).
4. Enter Affiant's Nevada driver's license or identification number.
5. Enter the Affiant's current physical address.
6. Enter the Affiant's current mailing address.
7. Affiant's signature.
8. An Erasure Affidavit must be signed in the presence of a Notary Public or authorized Nevada Department of Motor Vehicles representative. If witnessed by a Notary Public, the stamp and signature of the Notary Public must appear on the affidavit. If witnessed by an authorized Department representative, the name and validation stamp or employee identification number, as applicable, must appear on the affidavit.



555 Wright Way
 Carson City, NV 89711
 Reno/Sparks/Carson City (775) 684-4DMV (4368)
 Las Vegas area (702) 486-4DMV (4368)
 Rural Nevada or Out of State (877) 368-7828
www.dmv.nv.com

ERASURE AFFIDAVIT

NRS 482.245

An individual taking full responsibility for an error, change, or removal of information on ownership documents must complete and sign the Erasure Affidavit. If a person is being removed from the ownership documents, that individual is required to sign the affidavit. When representing a business, the business name and the name of the authorized business representative must appear on the affidavit.

Please print or type

(1) Year _____ Make _____ Model _____

Vehicle Identification Number _____

The undersigned, being duly sworn, states that the error or change appearing on the attached ownership documents for the described vehicle was made due to: (PLEASE STATE AREA CHANGE WAS MADE IN)

(2) _____

I declare under penalty of perjury that the foregoing is true and correct.

(3) Affiant's Printed Full Legal Name _____

(4) Nevada Driver's License, Identification Card Number, Date of Birth, or FEIN for businesses _____

(5) Physical Address _____
City State Zip Code

(6) Mailing Address _____
City State Zip Code

(7) Affiant's Signature _____ Date _____

(8) State of Nevada, County of _____

Signed and sworn to before me this _____ day of _____ 20__ by _____

Notary Public or Authorized Nevada DMV Representative

VP-019 (8/2011)

Lien Release / Satisfaction of Lien

Lien Release means a written release from a person, business, or financial institution on record as having a security interest in a vehicle. The lien release must include a complete vehicle description.

A lien release or satisfaction of lien enables a lienholder to release the security interest in a vehicle. It may be used with the Certificate of Title or with an application for a duplicate Certificate of Title.

Lien Release means a written release from a person, business, or financial institution on record as having a security interest in a vehicle. The lien release must include a complete vehicle description.

A lien release or satisfaction of lien enables a lienholder to release the security interest in a vehicle. It may be used with the Certificate of Title or with an application for a duplicate Certificate of Title.

Instructions for Completing Form VP-186

The lien release must include:

1. Enter complete description of the vehicle, including the vehicle identification number, year, make, and model.
2. Enter registered owner's full legal name
3. Enter registered owner's address.
4. Enter printed name of the lien holder,
5. Enter lien holder's address.
6. Enter lien holder's telephone number.
7. Enter printed name of the lien holder's representative.
8. Enter title of lien holder's representative.
9. The signature of an authorized representative of the business and date document was signed.
10. Signature must be witnessed by a Notary Public or authorized Nevada DMV representative.

Note: A Lien Release (Form VP-186) is available from the Department. However, other forms will be accepted provided they contain the information specified above.



555 WRIGHT WAY
CARSON CITY, NV 89711-0700
Reno/Sparks/Carson City (775) 684-4DMV (4368)
Las Vegas Area (775) 486-4DMV (4368)
Rural Nevada or Out of State (877) 368-7828
www.dmvnv.com

LIEN RELEASE

Please print or type

This is to certify the lien against the described vehicle has been fully satisfied.

(1) Vehicle Identification Number

Grid for Vehicle Identification Number

Year _____ Make _____ Model _____

(2) Registered Owner(s) _____
First Name Middle Last

(3) Address _____
Street City State Zip Code

(4) Printed Name of Lienholder _____

(5) Address _____
Street City State Zip Code

(6) Daytime Telephone Number (____) _____ - _____

(7) Lienholder Representative's Name _____
First Name Middle Last

(8) Lienholder Representative's Title _____

(9) Lienholder Representative's Signature _____ Date _____

(10) Subscribed and sworn before me this _____ day of _____ 20 _____

Notary Public or Authorized Nevada DMV Representative

Power of Attorney

A Power of Attorney is a written legal document whereby one individual conveys to another the legal right to act on his or her behalf.

If the right to release interest in a vehicle has been conveyed to another person or firm by Power of Attorney, the original Power of Attorney must accompany the title document, and it must contain a complete description of the vehicle, including the vehicle identification number, year, make, and model. The Power of Attorney may only be exercised on the Certificate of Title or document for which the authority was granted, otherwise, it is null and void.

If a general Power of Attorney is used to convey an individual's legal rights, an original or certified photocopy attached to the title document is acceptable.

The agent of a Power of Attorney shall furnish on demand an affidavit stating the Power of Attorney being relied on is a true copy and that, to the best of the agent's knowledge, the principal is alive and the relevant powers of the agent have not been altered or terminated.

A Power of Attorney becomes null and void upon the death of the individual who conveyed his or her rights to another.

The Power of Attorney must be exercised by the person or firm named as representative on the form. To properly exercise the Power of Attorney, the name of the owner must be listed prior to that of the representative.

- Example for an individual:
Sharon Smith by Jane Doe, P of A
- Example for a business:
Sharon Smith by Morrison's Garage George Morrison, P of A

The Power of Attorney must be witnessed by a notary public or authorized Nevada Department of Motor Vehicles employee or representative.

When the Power of Attorney is used to release ownership of a vehicle, the Certificate of Title must be signed in the appropriate area by the individual appointed as power of attorney.

If a specific Power of Attorney is used to release ownership of a vehicle, only certified or original copies are acceptable. The following statement must be included on the certified copy:

"I hereby certify that this is a true and exact copy of the original that is being held in our files. I further certify the original will be available during normal business hours for review by Department of Motor Vehicles personnel if necessary."

If a Power of Attorney is given to a business, the certification statement must include the business stamp or the printed or typed name of the business, the signature of the individual authorized to act on behalf of the business and the printed or typed name of the person certifying the copy of the specific Power of Attorney.

A general or specific power of attorney cannot be used to disclose the odometer reading on vehicles nine years old or newer when the title is not present.

When a title is not present a Secure Power of Attorney must be used to disclose an odometer reading on vehicles that are nine years old or newer.



555 WRIGHT WAY
CARSON CITY, NV 89711-0700
Reno/Sparks/Carson City (775) 684-4DMV (4368)
Las Vegas Area (702) 486-4DMV (4368)
Rural Nevada or Out of State (877) 368-7828
www.dmvnv.com

POWER OF ATTORNEY

Please print or type

KNOW ALL MEN BY THESE PRESENTS

That the undersigned, _____

in the County of _____ State of _____

being the Registered and/or Legal Owner of the following described motor vehicle:

Year _____ Make _____ Model _____

Vehicle Identification Number _____

Does hereby make, constitute and appoint _____

of the County of _____ State of _____

true and lawful Attorney in Fact to sign in the name, place and stead of the undersigned, any Certificate of Title or Vehicle Registration Certificate issued by the Department of Motor Vehicles of the State, covering the motor vehicle described above, in whatever manner necessary to transfer any Registration Certificate or Certificate of Title. Granting and giving unto said Attorney in Fact, full authority and power to do and perform any and all other acts authorized hereby, as fully to all intents and purposes as the grantor might, or could do if personally present, with full power of substitution.

Note: This form may not be used to disclose the odometer reading of a vehicle.

Full Legal Name _____
First Middle Last

Nevada Driver's License, Identification Card
Number, Date of Birth, or FEIN for businesses _____

Physical Address _____
Street City State Zip Code

Mailing Address _____
Street City State Zip Code

Signature of Applicant _____ Date _____

Subscribed and sworn to before me this _____ day of _____ 20 _____

Notary Public or Authorized Nevada DMV Representative _____

VP136 (Rev. 6-2011)

Vehicle Inspection Certificate Form VP-15

Vehicle Inspection Certificate (Form VP-15) is a form provided by the Department and when completed shows evidence that a vehicle inspection was completed by a DMV inspector or an authorized representative (including law enforcement) to verify the vehicle identification number.

Verification of the vehicle identification number (VIN) will be confirmed by a physical inspection of the vehicle.

The physical inspection of the vehicle must be completed by a Nevada DMV employee or authorized Nevada DMV representative.

Verification of the VIN ensures the accuracy of the information used to create a Nevada Certificate of Title.

Instructions for Completing Form VP-15

1. Enter the year, make, model, and body type of vehicle.
2. Low Speed Vehicles must meet safety standards set forth in Federal Motor Safety Standard No. 500 at 49 C.F.R. § 571.500 and if registered in Clark or Washoe Counties must pass an emission test.
3. Enter the complete Vehicle Identification Number (VIN) as it appears on the vehicle. Do not use other documents to retrieve this information. After inspecting the vehicle, compare the VIN from the vehicle to that on the other title documents to ensure they match.
4. Enter the odometer reading as it appears on the vehicle's odometer apparatus.
5. Select the odometer brand.
6. Enter whether the vehicle has cylinders or rotors and how many.
7. If the vehicle is a trailer, indicate whether the vehicle has living quarters or not.
8. Select the type of fuel this vehicle is powered by, if applicable.
9. Remarks: Comment on any unusual circumstances encountered during the inspection.
10. Authorized Officer-Inspector: The name of the authorized individual who completed the inspection.
11. Enter the badge number of the officer or employee ID of the authorized individual who completed the inspection.
12. Authorized Officer-Inspector: The signature of the authorized individual who completed the inspection.
13. Enter date of when the inspection was conducted.
14. Address of the authorized individual who completed the inspection.
15. Record the name of the agency conducting the inspection. Indicate whether the agency is law enforcement or an authorized agency such as a licensed Nevada dealer.



555 Wright Way
Carson City, NV 89711
Reno/Sparks/Carson City (775) 684-4DMV (4368)
Las Vegas Area (702) 486-4DMV (4368)
Rural Nevada or Out of State (877) 368-7828
www.dmvnv.com

IMPORTANT NOTICE: NEVADA LAW REQUIRES REGISTERED OWNERS TO MAINTAIN CONTINUOUS INSURANCE
COVERAGE ON REGISTERED VEHICLES, FROM A LICENSED NEVADA INSURANCE COMPANY TO AVOID PENALTIES
NRS 482.220

VEHICLE INSPECTION CERTIFICATE
FOR VEHICLE IDENTIFICATION NUMBER VERIFICATION

(To be completed by an Authorized Nevada DMV Representative or any Law Enforcement Officer)

Please Print or Type

I certify that I have examined the following vehicle:

1 Year _____ Make _____ Model _____ Body Type _____

2 Federal Certification Safety Label and Emissions Label (LSVs only) Yes No

Vehicle Identification Number

3 [Grid for Vehicle Identification Number]

4 Odometer Reading (as shown on apparatus) [Grid] NO TENTHS

If the vehicle's odometer apparatus only displays five numbers, please put an X in the first box. Not all LSVs will have an odometer.

5 1. The mileage stated is in excess of its mechanical limits.
 2. The odometer reading is not the actual mileage. WARNING - ODOMETER DISCREPANCY
 3. Exempt - Model year over 9 years old.

6 Cylinders _____ Rotor _____

7 If vehicle being inspected is a trailer, does it include living quarters? Yes No

8 Fuel: Gas Diesel Propane Electric Other (see remarks)

9 REMARKS _____

10 Authorized Officer-Inspector - Printed Name _____ Badge or ID # 11

12 Authorized Officer-Inspector - Signature _____ Date 13

14 (If other than DMV Inspection Station) _____
Address City State Zip Code

15 Enforcement Agency _____ Agency
 Nevada Authorized Agency _____ Agency

VP15 (Rev. 3/2011)

Section IV

Fees

Title Fees

NRS 482.429 and 487.810

Title Fees:

- | | |
|---|---------|
| • First-time, change of ownership, or duplicate certificates of title | \$20.00 |
| • Vehicles not physically present in or registered in Nevada | \$35.00 |
| • Salvage Title | \$10.00 |
| • Title Processing Fee | \$8.25 |

A title fee must be submitted for the following transactions:

- Vehicles sold or leased to a governmental agency including city, county, state, etc.
- All unregistered vehicles.
- Commercial vehicles registered by the Motor Carrier Division of the Nevada Department of Motor Vehicles.
- Lease terminations.
- Vehicles being titled in a dealership's name.
- Repossessed vehicles.
- Unregistered vehicles being titled to perfect a lien against the vehicle.
- Applications for a duplicate Nevada Certificate of Title, unless Form VP-206 is presented.
- All private-party transfers and dealer sales.

A Title Processing Fee must be charged on all title transactions that include a complete change of ownership. Do not charge a Title Processing Fee for:

- Salvage titles
- Non-repairable vehicle certificates
- Duplicate titles
- Removing a lienholder
- Removing a name (if one name from the original title remains on the new title)
- Changing a last name if person is "one-in-the-same" (e.g., married, legal name change)
- Changing an address
- Manufacturer's Statement of Origin or Manufacturer's Certificate of Origin is in the registered owner's full legal name.

No title fees are assessed for a Salvage Title issued to a license Nevada automobile wrecker, Non-Repairable Vehicle Certificate, or Junk Certificate.

Section V

Abandoned Vehicle and

Lien Sales

Lien Sales

Any person who is entitled to impose a lien on a motor vehicle as provided for in Nevada Revised Statutes 487 or 108 may, without process of law, detain the vehicle in his possession until the sum due to him is paid. If the sum due is not paid the lien may be satisfied by a sale.

If a motor vehicle that is placed in storage was towed at the request of a law enforcement officer following an accident involving the motor vehicle, the operator shall not:

- a) Satisfy any lien or impose any administrative fee or processing fee with respect to the motor vehicle for the period ending 4 business days after the date on which the motor vehicle was placed in storage ; or
- b) Impose any fee relating to the auction of the motor vehicle until after the operator complies with the notice requirements set forth in NRS 108.265 to 108.367, inclusive.

The following information is intended to help you process a lien sale in a minimum amount of time, while meeting all statutory requirements. Samples of letters and forms are provided for your convenience.

Notice of Lien Sale NRS 108.310

A lien claimant is required under NRS 108.310 to give written notice to the Department of Motor Vehicles of their lien. The notice must be given to the Department at the time the written notice is made to the registered and legal owner of the vehicle.

The Notice must include:

1. A vehicle description which includes the:
 - a) Vehicle Identification Number
 - b) Make
 - c) Year
2. License plate number, if attached
 - a) State of issue
 - b) Expiration date
3. Impound date
4. Party requesting tow
5. Date, time and location of auction

A sample Notice of Lien Sale is included. You may copy the sample for your use or use a similar format. If you do not use the sample, please include all information as listed.

The notice is to be mailed to:

Department of Motor Vehicles
Central Services and Records Division
Title Section – Lien Sale Notice
555 Wright Way
Carson City, NV 89711

Notice of Lien Sale

Business Name _____ Date _____

Address _____

Telephone Number _____ Business License Number _____

Auction Date, Time & Location _____

VIN	Year	Make	LIC PLATE #	EXPIRATION DATE	IMPOUND DATE	REQUESTED BY

Towing Abandoned Vehicles NRS 487.095 and NAC 487.030

Nevada licensed Automobile Wreckers and Tow Car Operators, who remove abandoned vehicles from public or private property as prescribed by NRS 487.230, may place a lien on the vehicle for towing and storage charges.

The vehicle must be declared abandoned on public property by a law enforcement agency or on private property by the property owner or person in lawful possession of the private property. NRS 258.125 entitles a \$50 fee be paid to a constable who requests a vehicle be removed from public property, after the lien has been satisfied.

Whenever a vehicle has been removed to a garage or other place as provided by NRS 487.230, the owner of the garage or the automobile wrecker who towed the vehicle has a lien on the vehicle for the costs of towing and storing, for a period not exceeding 90 days.

Nevada Administrative Code 487.030 sets towing fees at a fixed rate of \$55, regardless of the time of day, the distance to the vehicle or the type of equipment used to tow the vehicle.

For every abandoned vehicle, a tow company or wrecker must have in their possession one of the following documents as proof the vehicle qualifies as an abandoned vehicle;

- Impound Report for a law enforcement ordered impound of an abandoned vehicle. The law enforcement agency impound report identifying the vehicle impounded as an "abandoned vehicle".
 - If a vehicle is impounded for some other reason, the impound report will indicate that fact i.e., "impounded" or "stored" and the appropriate box on the form will be checked. For those categories of tow, there should be an explanation written on the form describing whether or not there are holds on the vehicle and the terms or conditions for release of that vehicle. Vehicles impounded by law enforcement or other enforcement agencies that are not classified "abandoned" may only be processed by a tow company or wrecker in accordance with the provisions of NRS 108.265 to NRS 108.367 inclusive. Such vehicles include but are not limited to, vehicles impounded and stored as a result of a traffic accident, traffic citation, arrest, or for any reason not classified as "abandoned". Such impounds may NOT be reclassified or the reason for towing changed, to allow the vehicle to be processed as an abandoned vehicle.
- If an abandoned vehicle has been towed as a result of a property owner or property managers, request to remove an abandoned vehicle from their private property, a "PRIVATE PROPERTY ABANDONED VEHICLE RELEASE" (POR) form is required by the Department as proof of a private property abandoned vehicle impound.

- Where the abandoned vehicle towing/storage lien packet is submitted by the owner of a garage, a completed “Abandoned Vehicle Lien Transfer” form VP-262, must accompany the lien packet showing the tow company or automobile wrecker has released their lien on the vehicle to the garage. This form would not be included for a mechanic’s or repair lien.

When requesting a vehicle appraisal or junk certificate, a DMV Appraiser may request documents from a tow company operator or wrecker, to support their acquisition of an abandoned vehicle listed on the companies abandoned vehicle transmittal sheet. If such a request is made, the tow company operator or wrecker must provide either a “POR” or the police impound report indicating the vehicle was abandoned.

The DMV Appraiser may request additional documents to support the tow company or wreckers, acquisition of a vehicle. If a tow company operator or wrecker refuses or is unable to produce the required, or additional supportive documents that support the tow company or wrecker's possession of a vehicle, the DMV Appraiser may refuse to appraise that vehicle.

The only alternative to the law enforcement impound or private property abandoned vehicle release would be an order issued by a court having jurisdiction, declaring a vehicle or group of vehicles be removed from private or public property as abandoned vehicles.

Authority to Recover Claim not Paid by Sale

The remedy for enforcing the lien provided in NRS 108 does not preclude any other remedies allowed by law for the enforcement of a lien against personal property, nor bar the right to recover so much of the lien holder’s claim as is not paid by the proceeds of the sale of the property.

Validity may be Contested NRS 108.350

Nothing contained in NRS 108.270 to 108.360 precludes the owner or any other person having an interest or equity in the property, from contesting the validity of the lien. Upon receipt of the filing of a court document showing an interested party has contested a lien, the Department will place a “flag” on the vehicle record to prevent transfer until the court determines the legal owner.

Private Property Abandoned Vehicle Release

"Private Property Abandoned Vehicle Release" or (POR) form;

- The POR is used by the tow company or wrecker when they are requested to remove an abandoned vehicle or vehicles by a private property owner or property manager.
- With the exception of the spaces provided for "Registered and/or Legal Owner" information, which may not be known for abandoned vehicles, the form must be completed in its entirety.
- The form is maintained as a record of the tow company or wreckers authorization to remove a vehicle from private or public property. The POR must be produced when requested by a DMV Appraiser or law enforcement officer making inquiries regarding the vehicle or its removal from private or public property.

PRIVATE PROPERTY ABANDONED VEHICLE RELEASE

I, the undersigned, do hereby release to _____
Name of automobile wrecker or tow car operator

the following vehicle:

Vehicle Identification Number

--	--	--	--	--	--	--	--	--	--	--	--	--	--	--	--	--	--

Year _____ Make _____ Model _____

License Plate Number

--	--	--	--	--	--	--

Expiration date _____ State _____

Registered Owner(s)

Name _____

Address _____
Address City State Zip Code

Legal Owner

Name _____

Address _____
Address City State Zip Code

Address of Property the vehicle was removed from

Address _____
Address City State Zip Code

Name of person requesting tow _____

I further save and hold (business name of automobile wrecker or tow company)

_____ harmless and direct them to remove the vehicle from my property.

Signature _____ Date _____

Property Owner's Printed Name _____

Notification Abandoned Vehicle Liens

As prescribed by NRS 706.4479, automobile wreckers, and tow car operators, must make every reasonable attempt and use all resources reasonably necessary, as evidenced by written documentation, to obtain the identity of the owner and any other necessary information from the agency charged with the registration of the motor vehicle in this State or any other state within:

- 21 days after placing the motor vehicle in storage if the motor vehicle was towed at the request of a law enforcement officer following an accident involving the motor vehicle; or
- 15 days after placing any other motor vehicle in storage.

The tow operator or wrecker, shall attempt to notify the owner of the vehicle by registered or certified mail as soon as possible, but in no case later than 15 days after identification of the owner is obtained for any motor vehicle. Pursuant to NRS 706.4477, if a request to tow is by the owner or agent of the owner of real property, it is presumed the registered owner abandoned the vehicle, and is responsible for the cost of removal and storage. The registered owner may rebut the presumption by showing, that he transferred his interest in the motor vehicle or, proof the vehicle was stolen.

If an operator includes in his tariff a fee to be charged to the registered and legal owner of a vehicle for the towing and storage of the vehicle, the fee may not be charged:

- For more than 21 days after placing the motor vehicle in storage if the motor vehicle was towed at the request of a law enforcement officer following an accident involving the motor vehicle; or
- For more than 15 days after placing any other vehicle in storage,
- Unless the operator complies with the notification requirements.

Note: The 15 days referred to in this section under “Abandoned Vehicle Liens” should not be confused with, or applied to, NRS 487.210 when defining an abandoned vehicle, and does not qualify a vehicle as abandoned should there be no response to the notice sent. In order for the provisions of NRS 487.250, subsections 3 and 4 to apply, the vehicle must first be included on an abandoned vehicle transmittal form, be confirmed by a Department representative as acquired by the Tow Company, or wrecker, as an abandoned vehicle, then appraised by a Department representative at a value of \$500 or less.

NRS 706.4468 allows the Nevada Transportation Authority to reduce any charge for preparing or satisfying a lien which is filed by the tow operator, if the Nevada

Transportation Authority determines that all or part of the charge is attributable to the operator's failure to prepare or satisfy the lien in a timely manner.

Requirements for the Tow Bill

The tow bill issued by a licensed Nevada Automobile Wrecker must be completed in full, and must contain the following information:

- Business name, address, telephone number and certificate number or DMV business license number.
- Address of the facility where the vehicle is stored.
- Date and time of the request for towing including designations to "am" or "pm".
- Name and address of the registered owner of the towed vehicle, if available.
- The year, make, model, vehicle identification number, license plate number and state of issuance.
- Exact location from where vehicle was towed.
- Address of the location to which the vehicle was towed, if different from the where the vehicle is being stored.
- The time the wrecker was dispatched to tow the vehicle and the reading of the odometer of the tow vehicle at the beginning of the trip.
- The time of the arrival of the tow car at the site of the car to be towed and the reading on the odometer upon its arrival.
- The time of the departure of the tow car from the site of the vehicle to be towed.
- The time of the arrival of the tow car at the location to where the vehicle was towed and the reading of the odometer upon its arrival.
- The total time, this passes while at the site of the towing in hours and minutes.
- The exact mileage and hourly charges.
- If an extra person was required, the time he was sent to the site and the time he returned.

- A detailed listing of all charges and, if charges are based on time, the starting and ending times. If more space is needed for the listing, a separate sheet of paper must be attached to the bill and a notation made on the bill that an additional sheet is attached. If the tow was requested by a constable, include the \$50 fee.
- The date and time the storage of the vehicle started, ended, and a notation of whether the vehicle was stored inside a locked building or in a secured, fenced area.
- Statement of total charges for towing.
- Of the action the registered and legal owner of the vehicle may take to recover his vehicle while incurring the lowest possible liability in accrued assessments, fees, penalties or other charges, and
- Of the opportunity to rebut the presumptions set forth in NRS 487.220 and 706.4477.

Abandoned Vehicle left at Salvage Yard

When an insurance company has relinquished all claims and interests to a vehicle, because of a lack of coverage, claim denial or similar reason:

The insurance company or their agent shall send a notice by means of registered, or certified mail to the last known address of record on file with the Department or other State of jurisdiction of the vehicle, to the legal and registered owners of the vehicle, and to the salvage pool or other place of storage of the vehicle indicating the insurance company relinquishes all claims and interest in the vehicle;

- The notice sent to the registered and legal owners of the vehicle must specify the address of the salvage pool, or other place of storage of the vehicle together with the conditions for the release of the vehicle.
- The notice shall specify a period of time, not to exceed 15 days from the date of receipt of the notice, for the registered or legal owner(s) of the vehicle to respond and make arrangements for removal of the vehicle from the salvage pool or other place of storage of the vehicle.
- Should the registered or legal owner of the vehicle fail to respond to the notice, or should the registered or legal owner of the vehicle fail to make arrangements to recover the vehicle from the salvage pool or other place of storage within the 15 days specified in the notice, the insurance company or its agent shall;
 - Forward a copy of all correspondence and return receipts for delivery of the registered or certified mail, together with verification of the legal address of the

registered and legal owners of the vehicle, to the salvage pool or other place of storage of the vehicle.

- Upon receipt of all documentation specified, the salvage pool, or other place of storage of the vehicle, shall have the option to;
 - Dispose of the vehicle in accordance with the provisions of NRS 108.265 to NRS 108.367, inclusive, or;
 - Declare the vehicle to have been abandoned on their property, and;
 - Have the vehicle removed by a licensed wrecker or tow company and processed as an abandoned vehicle, in accordance with the provisions of NRS 487.230.
- In the case of a vehicle for which there has been settlement of a claim but the owner retains ownership of the vehicle and the insurance company thereafter relinquishes all claims and interest in the vehicle, or;
- The owner of the retained salvage vehicle fails to reclaim and remove or cause to be removed the vehicle from the salvage pool;

It remains the insurance company's responsibility to secure a salvage title for these vehicles in the name of the owner.

- In the case of a vehicle for which insurance claims have been settled, but for which no title has been secured within the specified time limit and compliance with NRS 487.800 is not possible. These cases become a matter for the courts to determine and the following is required. The insurance company or its agent must secure a court order requiring DMV to issue a salvage title in the name of the insurance company.

Letter of Transmittal for Abandoned Junk Vehicles Form VP-162

Transmittal forms must be submitted to the nearest full service branch of the Department of Motor Vehicles, Field Services Division. Appraisals will be completed within 10 business days of receipt of transmittal. Only vehicles qualified as "abandoned" (NRS 487.210) will be appraised. Automobile wreckers, or tow companies, must provide proof of abandonment and have possession of the vehicle. Only those vehicles that a vehicle identification number has been ascribed, and qualify as an abandoned vehicle, will be inspected.



555 Wright Way
 Carson City, NV 89711
 Reno/Sparks/Carson City (775) 684-4DMV (4368)
 Las Vegas Area (702) 486-4DMV (4368)
 Rural Nevada or Out of State (877) 368-7828
www.dmvnv.com

LETTER OF TRANSMITTAL FOR ABANDONED JUNK VEHICLES
 NRS 487.240

Full Legal Name _____

Nevada DMV Wrecker or
 Tow Company's Business License Number _____

Physical Nevada
 Address _____
Address City State Zip Code

Mailing Address _____
Address City State Zip Code

Telephone _____ E-mail _____

Fax _____ Sent by _____ Date Sent _____

Vehicle Information				For DMV Use					
Vehicle Identification Number				Year	Make	Lic # & State	Registration Info		State RO/LO
1							<input type="checkbox"/> Yes	<input type="checkbox"/> No	
2							<input type="checkbox"/> Yes	<input type="checkbox"/> No	
3							<input type="checkbox"/> Yes	<input type="checkbox"/> No	
4							<input type="checkbox"/> Yes	<input type="checkbox"/> No	
5							<input type="checkbox"/> Yes	<input type="checkbox"/> No	
6							<input type="checkbox"/> Yes	<input type="checkbox"/> No	
7							<input type="checkbox"/> Yes	<input type="checkbox"/> No	
8							<input type="checkbox"/> Yes	<input type="checkbox"/> No	
9							<input type="checkbox"/> Yes	<input type="checkbox"/> No	
10							<input type="checkbox"/> Yes	<input type="checkbox"/> No	
11							<input type="checkbox"/> Yes	<input type="checkbox"/> No	
12							<input type="checkbox"/> Yes	<input type="checkbox"/> No	
13							<input type="checkbox"/> Yes	<input type="checkbox"/> No	
14							<input type="checkbox"/> Yes	<input type="checkbox"/> No	
15							<input type="checkbox"/> Yes	<input type="checkbox"/> No	

*** FOR OFFICIAL DMV USE ONLY ***

Date Postmarked _____ Date Received _____ Date Completed _____

Technician's Name _____ ID _____

Appraiser's Name _____ ID _____

This form may be photocopied

VP162 (Rev. 03-2012)

Appraisal Report for Abandoned Vehicle Form VP-161

This form is used for determining the value of vehicles declared abandoned pursuant to NRS 487.230.

Valuation will be noted as:

- Does not exceed \$200 – eligible for Junk Certificate if requested under NRS 487.260.5(e).
- \$500 or less – eligible for lien sale under NRS 487.250.4. To qualify under the provisions of NRS 487.250 a vehicle must;
 - Be acquired as a result of an abandoned vehicle tow, and;
 - Appraised by a Department representative as having a value of \$500 or less.
 - After the steps listed above have been completed in the order stated, the written notice specified in NRS 487.250 may be sent.
- Exceeds \$500 – eligible lien sale under NRS 108.

Vehicles Valued Under \$500

If the vehicle is appraised at a value of \$500 or less, the lien claimant is required to notify the registered and legal owner by registered or certified mail. The notice must include a statement the vehicle will be junked or dismantled or otherwise disposed of unless the registered or legal owner respond and pay the cost of removal.

Failure to reclaim the vehicle within 15 days after the notice was mailed constitutes a waiver of interest in the vehicle.

If the registered and legal owners have waived interest in the vehicle either by failure to respond to the notice or by written disclaimer, upon receipt of proper documentation the Department will issue a salvage title (value over \$201 but less than \$500) or junk certificate (value under \$200) to the automobile wrecker who towed the vehicle or a Certificate of Title to the garage owner if he elects to retain the vehicle and the vehicle is equipped as required by chapter 487 of NRS.

An example of a Notice of Lien is included. You may photocopy the form or create a form in similar format.

NOTICE OF LIEN VEHICLE VALUED UNDER \$500

Please print or type

Vehicle Identification Number

--	--	--	--	--	--	--	--	--	--	--	--	--	--	--	--	--	--	--	--

Year _____ Make _____ Model _____

License Plate Number

--	--	--	--	--	--	--

Expiration date _____ State _____

The above-described vehicle was acquired on _____ through a _____ agreement. As required by Nevada Revised Statute 108.272 this is to inform you that demand is being made for payment of \$_____ for services rendered by _____. This sum is due on _____; payment may be made at _____.

Below is an itemized statement of the lien costs incurred:

1. Tow charge or agreed service contract amount \$_____.
2. Storage fees \$_____, and accruing daily at the approved Public Service Commission rate.
3. Total lien fees \$_____.

Please be advised that if payment is not received on or before _____ the vehicle may be sold by auction at _____
 a.m. p.m., on _____ at _____
 or retained by lien claimant.

Lien Claimant _____

Business Name _____

Address _____
Address City State Zip Code

Telephone Number (_____) _____ - _____

Authorized Signature _____ Date _____

Vehicles Valued Over \$500

NRS 487.260 and 487.270

A lien claimant must notify the registered and legal owner the vehicle has been removed. The notice of lien must be delivered in person, verified mail and electronic mail if available addressed to the last known address of each person who holds a security interest in the vehicle. The notice must contain the following:

1. An itemized statement; showing the sum due at the time of notice and the date when it became due.
2. A brief description of the vehicle against which the lien exists which includes:
 - a) Vehicle year
 - b) Make
 - c) Vehicle Identification Number
3. Demand the amount of the claim as stated in the notice, and of any further claim as may accrue must be paid on or before a day mentioned.
4. A statement that unless the claim is paid within the time specified, the vehicle will be advertised for sale and sold by auction. The address, date and time of the auction must be specified.

An example of an acceptable Demand for Payment is provided. You may photocopy the example for your use or create a similar form.

DEMAND FOR PAYMENT

Vehicle Identification Number

Year _____ Make _____ Model _____

License Plate Number

Expiration date _____ State _____

The above-described vehicle was acquired on _____ through a _____ agreement. As required by Nevada Revised Statute 108.272 this is to inform you that demand is being made for payment of \$_____ for services rendered by _____. This sum is due on _____; payment may be made at _____.

Below is an itemized statement of the lien costs incurred:

1. Tow charge or agreed service contract amount \$_____.
2. Storage fees \$_____, and accruing daily at the approved Public Service Commission rate.
3. Total lien fees \$_____.

Please be advised that if payment is not received on or before _____ the vehicle may be sold by auction at _____
 a.m. p.m., on _____ at _____
 or retained by lien claimant.

Lien Claimant _____

Business Name _____

Address _____
Address City State Zip Code

Telephone Number (_____) _____ - _____

Authorized Signature _____ Date _____

Verified Mailing

Verified mail means any method of mailing offered by the United States Postal Service that provides evidence of mailing. Electronic Mail means an electronic message executable program, or computer file, which contains an image of a message that is transmitted between two or more computers or electronic terminals, or within or between computer networks, and from which a confirmation of receipt is received. While NRS 108.476 allows the notice to be sent electronically, it also requires the notice to be sent using the United States Postal Service. Acceptable proofs of verified mailing are:

- The returned un-opened letter,
- The green returned receipt, signed by the accepting party,
- The white copy of the certified mailing, stamped by the post office, or
- Log book listing certified mailings stamped by the post office.

If the notice is delivered in person a written statement is required which includes:

- Date of delivery,
- Place of delivery (complete address),
- Name of individual who accepts the notice,
- Name of individual who delivered the notice,
- Signature of person accepting the notice, and
- Signature of individual who delivered the notice.

Advertisement of Sale NRS 108.310

After the time for payment of the claim specified in the notice has elapsed and the registered and legal owners have not satisfied the claim, a "Public Auction Sale" advertisement must be published once a week for 3 consecutive weeks. The advertisement must be published in a newspaper circulated in the place where the sale is to be held. If no newspaper is published in that place, then the advertisement must be placed in a newspaper published in this state that is circulated in the place the sale is to be held.

The sale must not be held less than 22 days after the first date of publication.

The advertisement must:

- Describe the vehicle.
- State the names of the registered and legal owners.
- State the date, time and place of the sale.

Example of Publication

NOTICE OF SALE

Notice is hereby given to the last
Registered and Legal Owner of:
1997 Chevy Monte Carol
VIN 1H67K3ZA6999999
R/O J. Q. Smith
L/O Bank in Nevada

The vehicle described above will be sold at
a public auction to the highest bidder to
satisfy the lien incurred by name of
automobile wrecker or towing company.
The sale will be held at time including am
or pm on month/day/year at exact location
of the sale.

Affidavit of Publication

The newspaper that publishes the advertisement of sale must provide the lien claimant with verification the advertisement was published and the date of publication.

Example of Affidavit of Publication

Attach article here

STATE OF NEVADA } COUNTY OF CLARK }	ss
_____, being first duly sworn, deposes and says:	
That she/he is a legal clerk for the LAS VEGAS GAZETTE and THE LAS VEGAS COURIER, daily newspapers regularly issued, published and circulated in the city of Las Vegas, County of Clark, State of Nevada, and the advertisement, is a true copy of which is attached, was continuously published in the LAS VEGAS GAZETTE or THE LAS VEGAS COURIER, on the following days:	

Signed: _____	
Subscribed and sworn to before me this _____ day of _____, _____	

Notary Public or Authorized Nevada DMV Representative	

Sale by Public Auction **NRS 108.310**

Once all statutory requirements have been met, the Public Auction sale may take place. The sale must be held at the time and date that all notices have indicated. The location must be where the lien was acquired or, if that place is unsuitable, at the nearest suitable place.

The lien claimant may satisfy his lien from the proceeds of the sale, including reasonable charges of notice, advertisement and sale. The balance, if any of the proceeds must be delivered, on demand to the registered and/or legal owner.

Submitting Lien Sale Documents **NAC 108.110**

The Lien Sale Affidavit, and the other lien documents, must be submitted to the Department within thirty-days from the date of the sale of the vehicle. The title fees must also be submitted with the Lien Sale Affidavit and other lien sale documents, the standard title fee is \$20, plus an \$8.25 processing fee. The salvage title fee is \$10. When a licensed Nevada wrecker purchases the vehicle, give the lien packet to the wrecker. The wrecker will submit the lien sale packet to obtain a title at a later time.

Submit Lien Sale Affidavit and other lien documents to:

Department of Motor Vehicles
Central Services and Records Division
Titles Section
555 Wright Way
Carson City, Nevada 89711

Collecting Sales Tax **NAC 108.110**

Lien claimants must collect sales tax for the lien sale of a vehicle, using the tax rate for the county where the auction occurs. For more information regarding sales tax, contact the Department of Taxation at 775/684-2000.

Lien Sale Affidavit

Instructions for Completing the front of Lien Sale Affidavit formVP-147

1. Select the appropriate type of ownership document that is being requested by marking the box.
- NOTE:** Title fee is \$28.25, Salvage Title fee is \$10, and licensed Nevada wreckers Salvage Title fee is \$0.
2. Enter the full legal name of the business representative who is completing the affidavit.
 3. Enter the name of the business.
 4. Enter the DMV Business License number if your business is licensed or registered with DMV. If you do not hold a DMV business license, enter your Federal Employer Identification number (FEIN).
 5. Enter the business address.
 6. Enter the date the business physically acquired the vehicle.
 7. Enter the name of the person, who authorized the services that initiated the lien process, this also includes law enforcement.
 8. Enter the vehicle identification number.
 9. Enter the vehicle description including year, make, model, body type and number of cylinders.
 10. Enter the registered owners name and address.
 11. Enter the registered owners address.
 12. Enter the legal owners name
 13. Enter the legal owners address.
 14. Select what the charges are assessed for by marking the box in front of the type of lien. Note: A garage who is filing an abandoned vehicle lien would select Storage and must include the Abandoned Vehicle Lien Transfer form VP262.
 15. Enter the total of all charges that have incurred.
 16. Enter the date the vehicle was sold.
 17. Enter the amount the vehicle was sold for.
 18. Enter the amount of sales tax collected.
 19. Enter the title fee.
 20. Enter the total purchase price.
 21. Enter the purchaser's full legal name.
 22. Select and/or if the registration and title is in more than one name, the appropriate box must be marked to indicate "and" or "or."
 23. Enter Nevada Driver's License, Identification Card Number, or FEIN for businesses: Enter the number from the appropriate document. If the customer is not a business and does not have a Nevada Driver's License or Identification Card, write "None" on this line.
 24. Enter second purchaser's full legal name (if applicable).
 25. Enter Nevada Driver's License, Identification Card Number, or FEIN for businesses: Enter the number from the appropriate document. If the customer is not a business and does not have a Nevada Driver's License or Identification Card, write "None" on this line.

26. Enter the purchaser's physical address.
27. Enter the purchaser's mailing address.
28. Enter the new lienholder's name. If there is no lienholder, write "None" on the Lienholder Name line.
29. Enter the new lienholder's address.

Instructions for Completing the back of Lien Sale Affidavit formVP-147

1. Enter the odometer reading; do not include tenths of a mile.
2. Mark the appropriate box, which describes the odometer reading.
3. Select any condition that may be applicable to the vehicle.

Note:

- If the vehicle has been Rebuilt a Certificate of Inspection / Affidavit of Vehicle Construction form (VP-64) must accompany the Lien Sale Affidavit.
 - If the vehicle is Non-Repairable, the vehicle may only be sold to a licensed Nevada Automobile Wrecker.
4. If none of the conditions listed apply to the vehicle, select the affirmation.
 5. Select the box indicating whether the vehicle was registered or was not registered. If the vehicle was registered (currently or expired), enter the license plate number, expiration date, and state the vehicle was registered. If the license plate number or expiration date is unavailable, write "None" on the corresponding line.
 6. Enter the date the certified letter was mailed.
 7. Enter the first day the notice was published in the newspaper.
 8. Enter the name of the newspaper.
 9. Enter the address of the newspaper
 10. Enter the date of the public auction.
 11. Enter the full legal name of lien claimant,
 12. Enter the lien claimant's signature
 13. Enter the date lien claimant signed affidavit.
 14. To be completed either by a notary public or an authorized Nevada DMV representative.

Back of the form revised 6/2011

LIEN CLAIMANT'S CERTIFICATION

Federal law requires that you state the mileage upon transfer of ownership. Failure to complete or provide a false statement may result in fines and/or imprisonment. This vehicle was an involuntary transfer; at the time of sale the odometer reading:

Odometer Reading (as shown on apparatus) (1) _____ **NO TENTHS**

(2)

1. The mileage stated is in excess of its mechanical limits.
 2. The odometer reading is not the actual mileage. **WARNING – ODOMETER DISCREPANCY**
 3. Exempt – Model year over 9 years old.

To the best of my knowledge, at the time of lien sale this vehicle is *(select any that may apply)*

(3) Salvage Flood Damaged Total Loss Rebuilt Non-Repairable (Non-Repairable vehicles may only be sold to licensed automobile wreckers.)

(4) I have inspected the vehicle herein described and to the best of my knowledge and information do hereby certify and affirm the vehicle is NOT a Salvage, Flood Damaged, Total Loss, previously Rebuilt or Non-Repairable vehicle.

(5) The vehicle Was registered (current or expired) and the license plate number is _____.
 Expiration date _____ State _____

Or Was not registered.

(6) Date of Certified Mailing; _____ day of _____ 20____.

(7) *First Date of Newspaper Publication; _____ day of _____ 20____.

(8) Name of Newspaper _____

(9) Address _____
Address City State Zip Code

(10) Public Auction Date; _____ day of _____ 20____.

I hereby certify and affirm that all provisions of NRS 108.270 through 108.360 and 487.250 have been complied with, and make this affidavit for the purpose of satisfying the Nevada Department of Motor Vehicles that a Registration Certificate and/or Certificate of Title for the described vehicle should be issued to the purchaser upon the facts stated herein. I also hereby release, discharge and agree to hold harmless the Nevada Department of Motor Vehicles of and from any and all liability to anyone whomsoever which may arise by reason of any contest of the validity of the lien herein referred to, or the validity of the sale under said lien, or failure of Lien Claimant to satisfy lien in the manner prescribed in NRS and NAC 108.

(11) Printed Full Legal Name of Lien Claimant _____

(12) Signature of Lien Claimant _____ Date (13) _____

(14) Subscribed and sworn to before me this _____ day of _____ 20____

 Notary Public or Authorized Nevada DMV Representative

NOTE: This document must be accompanied with a completed Vehicle Inspection Certificate (Form RD-15). Nevada licensed wreckers, body shops, or garages do not have to provide a completed Vehicle Inspection Certificate.

Definition of Types of Liens

- Abandoned Vehicle means at the direction of any peace officer or with the release of a property owner who orders the towing or storage of any vehicle
- Keeper of a Trailer Park means a mobile home park, mobile home lot or other land for rental of spaces for trailers, mobile homes or manufactured homes
- Mechanics means a garage or place for the maintenance or repair of motor vehicles, motorcycles, motor equipment, or trailers, including the operator of a salvage pool
- Storage means the sum due for the storing, maintaining, or keeping of the motor vehicle, motorcycle, motor equipment, or trailer
- Tow means the sum due for the towing and storing of the motor vehicle, motorcycle, motor equipment, or trailer

*Not required for abandoned vehicle with an appraised value under \$500.

Lien Sale Registration Certification Form VP-201

The Lien Sale Registration Certification (VP-201) must be completed and given to the purchaser of the vehicle, to allow them to register the vehicle. The vehicle may not be driven without a permit, or vehicle registration. This form is not required when the purchaser is a licensed Nevada Wrecker.

In Clark and Washoe Counties inform the purchaser that the vehicle may not be registered without a passing emission test on file.

Instructions for Completing the Lien Sale Registration Certification form VP-201

1. Enter the full legal name of the business representative who completed the affidavit.
2. Enter the name of the business.
3. Enter the business address.
4. Enter the business's FEIN.
5. Enter the signature and date the business representative signed this certificate.
6. Enter the vehicle description including year, make, model, body type and number of cylinders.
7. Enter the vehicle identification number.
8. Enter the odometer reading; do not include tenths of miles.
9. Enter the purchaser's full legal name.
10. Select and/or if the registration and title is in more than one name, the appropriate box must be marked to indicate "and" or "or."
11. Enter Nevada Driver's License, Identification Card Number, or FEIN for businesses and telephone number. If the customer is not a business and does not have a Nevada Driver's License or Identification Card, write "None" on this line
12. Enter the purchaser's physical address.
13. Enter the purchaser's mailing address.
14. Enter the second purchaser's full legal name, if there is not one, leave lines 14 to 17 blank.
15. Enter second Nevada Driver's License, Identification Card Number, or FEIN for businesses and telephone number. If the customer is not a business and does not have a Nevada Driver's License or Identification Card, write "None" on this line
16. Enter the second purchaser's physical address.
17. Enter the second purchaser's mailing address.
18. Enter the Purchase Price.
19. Enter the Date of Sale.
20. Enter the amount of Sales Tax Collected.
21. Enter the amount of the title fees paid.
22. Enter the Total Purchase Price.
23. Signature and date the person from line 1.



555 Wright Way
 Carson City, NV 89711
 Reno/Sparks/Carson City (775) 684-4DMV (4368)
 Las Vegas area (702) 486-4DMV (4368)
 Rural Nevada or Out of State (877) 368-7828
www.dmvnv.com

**LIEN SALE REGISTRATION CERTIFICATION
 FOR VEHICLE REGISTRATION ONLY**

This document must be used by the Lien Claimant to allow the purchaser of a vehicle to register the vehicle sold at public auction pursuant to Nevada Revised Statute (NRS) and Nevada Administrative Code (NAC) Chapter 108.

Please Print or Type

(1) I, _____ on behalf of (2) _____
Name of Lien Claimant Name of Business

(3) Business Address _____ FEIN (4) _____
Address City State Zip Code

(5) Signature _____ Date _____
 certify under penalty of perjury that I have complied with all provisions of NRS 108 and NAC 108, and have sold the described vehicle at public auction.

(6) Year _____ Make _____ Model _____ Body Type _____ Cylinders _____

(7) Vehicle Identification Number

(8) Odometer Reading (as shown on apparatus) _____ **NO TENTHS**

NOTE: This vehicle cannot be operated without a certificate of registration or temporary movement permit and Nevada evidence of insurance in the name of the registered owner. To register this vehicle or obtain a temporary movement permit, please present this form to any full service branch of the Nevada Department of Motor Vehicles immediately after purchase. Clark and Washoe County residents may also require a Certificate of Compliance for Emission Control to register the vehicle.

(9) Purchaser's Full Legal Name _____ (10) and or
First Middle Last

(11) NV Driver's License, ID Card Number or FEIN for Businesses _____ Telephone Number _____

(12) Physical Address _____
Address City State Zip Code

(13) Mailing Address _____
Address City State Zip Code

(14) Purchaser's Full Legal Name _____
First Middle Last

(15) Nevada Driver's License, ID Card Number, Date of Birth, or FEIN for Businesses _____ Telephone Number _____

(16) Physical Address _____
Address City State Zip Code

(17) Mailing Address _____
Address City State Zip Code

Purchase Price \$ (18) _____ Date of Sale (19) _____
 Nevada Sales Tax Collected \$ (20) _____
 Nevada Title and Title Processing Fee \$ (21) _____
 Total Purchase Price \$ (22) _____

I, the Lien Claimant, will forward the Lien Sale Affidavit (VP-147), together with title fees collected pursuant to NRS 482.429, and other required documents to the Department of Motor Vehicles, Central Services and Records Division, Title Section within thirty days from the date of the sale of the above vehicle.

(23) Lien Claimant's Signature _____ Date _____

VP-201 (6/2011)

**This document is void if altered in any way
 THIS IS NOT AN OWNERSHIP DOCUMENT
 OR AUTHORITY TO OPERATE THE VEHICLE**

Request for Extension of Time for Submitting Lien Sale Documents Form OBL316

If a lien claimant is unable to submit the Lien Sale Affidavit and title documents to the Department within the statutory time frame, the lien claimant may request an extension of time.

Extension requests must be submitted within the statutory time frame, thirty days from the date of sale, required for submission of the Lien Sale Affidavit.

A request for an extension must be submitted to an Occupational and Business Licensing office, on a Lien Sale Extension Request (Form OBL-316). The request must explain why the lien claimant is unable to submit the required documents within the regulatory time frame. The lien claimant must sign the form. A photocopy of the Lien Sale Affidavit must accompany the request. Refer to NAC 108.120.

An extension should be requested only when absolutely necessary, and will be granted on an exception only basis. Lien claimants are required, by regulation, to send title documentation to the Department within the required time frame, and may be subject to an audit, administrative fine or administrative action against their business for failure to comply.

The Lien Sale Extension Request OBL-316 indicating approval or denial will be mailed to the lien claimant. If the request is denied, the reason will be marked on the extension form.

The sample form in this book may be photocopied for your use.

Print Form



Occupational and Business Licensing
555 Wright Way
Carson City, NV 89711
(775) 684-4690
www.dmvnv.com

LIEN SALE EXTENSION REQUEST

Date:
Lien Claimant Name:
Mailing Address:
Physical Address:
Business License Number (If applicable):
Date of Sale: Vehicle Year: Make:
VIN:
Reason extension is being requested (explain in detail):

Requested by:
Signed:
Signature of business principal or authorized representative Title of Authorized Representative

Note:
Extension requests must be submitted within thirty days from the date of sale.
A Photocopy of the Lien Sale Affidavit must accompany this form.

Do not write below this line, doing so will void extension request.

To be completed by Business and Occupational Licensing personnel only.

- The Business and Occupational Licensing Section has granted an extension of time in submitting this Lien Sale Affidavit until:
The Business and Occupational Licensing Section has denied an extension of time in submitting this Lien Sale Affidavit for the following reason(s):
Not submitted within the required time frame.
A photocopy of the Lien Sale Affidavit and Lien Sale Registration Certificate was not attached.
A detailed explanation for the delay in submitting extension request is required.
The reason given for the extension is not sufficient to have an extension granted and has been submitted to Compliance Enforcement Division office.
Request by or Signature line not completed.
Other:

Signed by: Date:

OBL316 (1/2006)

Section IV

Records Information

Accessing Department of Motor Vehicle Information

The Department of Motor Vehicles is authorized to maintain an information reporting service for driver's license and vehicle registration and title records. The Department's Central Services and Records Division, Records Section in Carson City is the only office authorized to release records.

To request records, an *Application for Individual Record Information* (Form IR-002) and *Affidavit* (Form IR-003) must be completed and submitted to the Department. The request must also document the requestor's legal right to the information. The application, affidavit and any supporting documentation and fees will be forwarded and processed by the Records Section in Carson City.

If a firm or company wishes to have an account with the Department, an *Application for Records Service* (Form IR-001) and an *Affidavit* (Form IR-003) must be completed, signed, notarized, and submitted to the Department. A copy of the current business license and/or private investigator's license must be submitted with the application and affidavit. The Department may request additional supporting documents.

- When the account is established, the applicant will be formally notified by letter.
- The notification will include the account number.
- Monthly-itemized statements will be sent to each account holder indicating services rendered by the Department for the previous month.
- Payments in full are due within 21 days from the date of the statement.
- Inquiries will not be processed without the account number and verification the requestor is an authorized user on the account.

Nevada law prohibits the release of license plate numbers or social security numbers.

For further information or forms visit our web site at www.dmvnv.com or contact us at:

Nevada Department of Motor Vehicles
Central Services & Records Division
Records Section
555 Wright Way
Carson City, NV 89711-0250
(775) 684-4590

Vehicle Registration, Title, and History Information

V1—VEHICLE REGISTRATION INFORMATION

This information is limited to the current registration records, including the year, make, expiration date, vehicle identification number and registered owner's name and address. To request this information, the following must be supplied:

A completed application, affidavit, and any supporting documents that the Department may require must accompany a request unless you have established an account with the Records Unit.

V2—VEHICLE TITLE INFORMATION

This information is limited to the current Nevada title records, including the name of the registered owner on the title, the name and address of the lienholder and the date the title was created. To request this information, the following must be supplied:

A completed application, affidavit, and any supporting documents that the Department may require must accompany a request unless you have established an account with the Records Unit.

V3—VEHICLE HISTORY

Upon request, research can be done to determine the first and subsequent registrations of the vehicle in Nevada, the documents used to register the vehicle or the documents used to title the vehicle, etc.

Customers maintaining accounts with the Department may request records by telephone at (775) 684-4590, or toll-free within Nevada at 1-800-992-7945. By fax at (775) 684-4899 or by mail at:

Department of Motor Vehicles
Central Services Records Division
555 Wright Way
Carson City, Nevada 89711-0250

Application for Records Service



CENTRAL SERVICES DIVISION
 RECORDS SECTION
 555 WRIGHT WAY
 CARSON CITY, NV 89711-0250
 (775) 684-4590
 www.dmvnv.com

APPLICATION FOR RECORD INFORMATION

A. Requestor Name _____
 Business Name (if applicable) _____
 Physical Address _____
 Mailing Address if Different: _____
 Phone # () _____ Fax # () _____ NAIC# (if applicable) _____

B. INFORMATION REQUESTED (Please mark appropriate box and fill out corresponding section)
Driver's License Information:
 Certification (S2) Microfilm (D5) (Must be requested with a Driver History Record) (Ex: Original application.)
 Driver License Info (D1)
 Clearance Letter (D3)
 Driver History Record (D2) Select one:
 3-Year History 10-Year History (Released to individual & law enforcement only) School Bus History

When requesting any of the above information, please provide the following identifying information:
 Full name _____ Date of Birth _____
 NV address _____
 NV Driver's License No. _____ Social Security No. _____

Vehicle Information:
 Vehicle Registration Printout (V1) Insurance Information
 Title Verification Letter (S4) Tax Information Receipt
 Vehicle Title Printout (V2) Plate Surrendered Receipt or Letter
 Vehicle History (Specify registration or title) Registration (V3a) Title (V3b)

Full Name _____
 NV address _____
 Year _____ Make _____ Vehicle I.D. No (VIN) _____

C. FOR WHAT PURPOSE IS THIS INFORMATION NEEDED?

I hereby declare under penalty of perjury that the information received will not be used for an illegal purpose or unwarranted invasion of a particular person's privacy nor will I release or sell any information received through this application to any other party for use by such party.

I agree to indemnify and hold the state of Nevada, Department of Motor Vehicles, its agents and employees from any all claims, causes of action, or liability arising from the careless, negligent or improper use by myself, my agents, of any of the information received under this application.

Signature of Requestor _____ Date _____
 (Request for information will not be processed without the signature of the requesting party)

#902 (10/2005)

Application for Individual Record Information
Affidavit



Central Services Records Section
555 Wright Way
Carson City, Nevada 89711-0250
(775) 684 - 4590
www.dmvnv.com

State of _____)
County of _____) §

AFFIDAVIT

Being first duly sworn under penalty of perjury I hereby state:

- (a) I have read, fully understand and agree to abide by the laws and regulations now in effect and hereinafter enacted or adopted regarding the manner in which personal information from the Department of Motor Vehicles driver's license, registration files and records may be obtained and the limited uses which are permitted;
- (b) I understand that any sale or disclosure of information so obtained must be in accordance with the provisions of this section. Specifically, that I must keep records of such sale or disclosure for five years for department inspection, and that such sale or disclosure may only be for a use permitted under law;
- (c) I understand that a record will be maintained by the department of any information which I request;
- (d) I understand that a violation of the provisions of NRS 481.063 and NRS 485.316 is a criminal offense. Specifically, that it is unlawful to make a false representation to obtain any information from the Department, or to knowingly obtain or disclose any information from the files or records of the department for any use not permitted by the provisions of this chapter.
- (e) The agency shall keep all data, information, reports, tests, manuals, instructions, plans, system designs, computer codes, and any documents or drawings received from the State of Nevada, Department of Motor Vehicles ("Department"), or created by the agency as necessary to render performance under this Agreement, strictly confidential. Except for the sharing of information among law enforcement agencies for law enforcement purposes, the agency agrees that it may not disclose any of the aforementioned items to a person who is not a party to this agreement absent the express written consent of the Department. The agency further understands and agrees that the Department may be required to disclose, in certain instances, some of the above items in compliance with Nevada Public Records Law, and these instances do not change the obligations of the agency to maintain confidentiality as set out above.
The confidential items, as set out above, specifically include, but are not limited to, the following items:
 - 1) Information regarding security passwords, security access codes, and security programs; access codes for software applications; and security procedures, processes, and recovery plans.
 - 2) Specific data collected in preparation of or essential to the Department's business.
 - 3) Security testing results, especially if the results identify specific system vulnerabilities.
 The agency also agrees and understands that this confidentiality provision's purpose is to prevent public disclosure that may have an impact on public safety or security, including but not limited to security of personal information. In addition to any other indemnification agreements contained in this Affidavit, The agency further agrees to indemnify, hold harmless, and defend the Department from and against all liability, claims, actions, damages, losses, and expenses, including, without limitation, reasonable attorneys' fees and costs, based on the agencies release of the aforementioned items. If the agency must disclose some of the above items to a third party, the agency shall obtain the written consent of the Department and the third party must agree, in writing, to the terms of this provision. The terms of this provision shall survive the completion of performance under this Agreement and/or the termination of this Agreement.

I attest to the fact that I am an authorized representative of the requesting agency. I declare under penalty of perjury that the foregoing is true and correct.

DATED this _____ day of _____, (20__)

Signature of Applicant _____ Printed Name and Title (if applicable) of Applicant _____

Signed and sworn to before me this _____ day of _____, (20__)

By _____

NOTARY Public or Authorized Nevada DMV Representative _____ (Notary Seal)

(R003) (1/28/03)

Records Section Fee Schedule



Central Services Record Section
 555 Wright Way
 Carson City, Nevada 89711-0250
 (775) 684 – 4590
www.dmvnv.com

GUIDELINES AND FEES FOR RECORD INQUIRIES

This guide is for the most effective use of Nevada records facilities. If you provide us with certain basic information, a record search can be accomplished in a very short period of time.

Identifiers for driver's license inquiries are:
 Driver's License Number
 Social Security Number
 Name, Date of Birth and address

Identifiers for registration/title inquiries are:
 Vehicle Identification Number (VIN)
 Registered Owner's Name and address

- D1 DRIVER LICENSE INFORMATION – provides information shown on the front of the driver's license. Fee: \$5.00
- D2 DRIVER RECORD INFORMATION – provides information shown on the front of the driver's license and convictions for the past three years. Fee: \$7.00
- D3 DRIVER LICENSE CLEARANCE LETTER – states Nevada record is clear to obtain a drivers license in other states. Fee: \$6.00
- V1 VEHICLE REGISTRATION INFORMATION – provides the year, make, model, expiration date and registered owner's name and address. Fee: \$5.00
- V2 VEHICLE TITLE INFORMATION – provides owner(s) name and address, and/or lienholder(s), name and address, title number, and date title was created. Fee: \$5.00
- V3 (a) REGISTRATION HISTORY Fee: \$7.00
- V3 (b) TITLE HISTORY Fee: \$7.00 - plus any additional research (S3) \$3.00 per page includes front and back.
- S2 CERTIFICATION OF DOCUMENTS Fee: \$4.00
- S3 Research Fee: \$3.00 per page includes front and back.
- S4 TITLE VERIFICATION LETTER – states no Nevada title has been issued to a specific vehicle. Fee: \$7.00

Social Security Numbers are not released. License plate numbers are not released, nor can information be obtained by the presentation of a license plate number; except to law enforcement agencies, governmental agencies processing parking violations, vehicle insurance companies, public administrators, public guardians, public defenders and private investigators. No information will be released when multiple listings are found on a search by name only where no positive match can be established.

Please make checks payable to the Department of Motor Vehicles, **RECORDS SECTION**.

Payment in full is due at the time record requests are submitted, except for requests charged to a Records Account. Monthly invoices will be issued for Records Accounts and payment in full is due within 21 days of the billing date. If your account is suspended for non-payment, you will be required to pay not only the past due amount, but any current invoice amounts before any further business can be conducted with the Department. In addition, per NRS 353C, your account will be turned over to a private collection agency. Accounts referred for private collection may be required to pay private collection fees. Accounts referred to the collection agency will remain suspended until proper notification of payment in full is received directly from the collection agency.

(R006 09/2011)

Section VII

Glossary/Index

Glossary

Abandoned Vehicle (NRS 487.210) as used in NRS 487.220 to 487.300, inclusive, unless the context otherwise requires, “*abandoned vehicle*” means a vehicle: 1. That the owner has discarded; or 2. Which has not been reclaimed by the registered owner or a person having a security interest in the vehicle within 15 days after notification pursuant to NRS 487.250.

Appraised Value means the estimated monetary value of a vehicle based on the condition of the vehicle utilizing publications that are common in the industry. A State of Nevada Vehicle Appraiser or an authorized representative appraises vehicles.

Appraiser (NRS 374.112) means an authorized employee of the Department of Motor Vehicles, a county assessor or his employee as an agent of the Department of Motor Vehicles, a person licensed by the Department of Motor Vehicles as a dealer or an independent *appraiser* authorized by the Department of Motor Vehicles.

Assigned VIN (Vehicle Identification Number) means a unique vehicle identification number (VIN) assigned by a DMV inspector or authorized representative when a vehicle is homemade or when the original VIN has been destroyed or obliterated.

Authorization for Vehicle Restoration (Form VP-209)(NRS 487.480) means a form provided by the Department that authorizes the restoration of a vehicle that is five years old or newer, pursuant to subsection 2 of NRS 482.553.

Authorized inspection station (NRS 445B.710) means a station licensed by the Department of Motor Vehicles for inspecting motor vehicles and devices for the control of pollution for compliance with this chapter or any applicable federal regulation or regulation of the Commission.

Authorized Representative means a person authorized by a principal of a Department Business Licensee to conduct business with the Department on behalf of the licensee. Some *authorized representatives* may be limited to only have authority to conduct certain types of transactions.

Authorized Station (NRS 445B.720) means a station licensed by the department of motor vehicles for inspecting motor vehicles and devices for the control of pollution

Bill of Sale means a document that releases interest in a vehicle. A Certificate of Title or other ownership documents must accompany a *Bill of Sale*. The *Bill of Sale* must also include a complete vehicle description.

Certificate of Inspection (Form VP-15) means a form provided by the Department and when completed shows evidence that a vehicle inspection was completed by a DMV inspector or an authorized representative (including law enforcement) to verify the vehicle identification number.

Certificate of Inspection/Affidavit of Construction for Rebuilt, Reconstructed, or Specially Constructed Vehicle (Form VP-64) is a form provided by the Department for the purpose of certifying, before a vehicle is issued a title; that:

- (1) A vehicle has had a proper safety inspection by a Nevada Registered Garage or Licensed Nevada Body Shop.
- (2) A Nevada Registered Garage or Licensed Nevada Body Shop has attested to the mechanical fitness of a vehicle.
- (3) An applicant declares where the parts came from on a rebuilt vehicle.

Certificate of Inspection and Affidavit of Construction for a Homemade or Assembled Trailer (Form VP-223) means a form provided by the Department for the purpose of certifying a trailer is equipped with all required safety items and is fit to be on public roads before a title is issued; that:

- (1) A trailer has had a proper safety inspection by a Nevada DMV Representative.
- (2) An applicant declares where the parts came from to construct the trailer.

Certificate of Title (Form RD-2) means a document provided by the Department that contains the information required by subsection 2 of NRS 482.245. This document is commonly referred to as a *certificate of title* or ownership.

Component Part means each part contained in or upon a vehicle, including but not limited to the engine or motor; the transmission or transaxle; the chassis, frame or load bearing major structural equivalent thereof; any door, hood deck lid, hatch or tailgate; any bumper; any fender or quarter panel; a cowl or firewall; a cargo compartment or passenger compartment floor or floor panel; and any motorcycle frame, front fork or crank case.

Crush means the compression, destruction or deformation of a vehicle.

Currently Registered means, for the purpose of issuing a junk certificate, a vehicle which has record of an un-expired registration in any jurisdiction. For the purpose of research it means a record of registration or ownership, expired or un-expired, in any researched jurisdiction.

Department means the Nevada Department of Motor Vehicles.

Destroy means the destruction or demolition of the vehicle beyond the point of repair or renewal.

Discard has the same meaning as 'abandoned vehicle' as found in NRS 487.210.

Dismantle means the removal of component parts from a vehicle for the purpose of monetary gain.

Electronic Mail (NRS 108.476) means an electronic message executable program or computer file which contains an image of a message that is transmitted between two or more computers or electronic terminals, or within or between computer networks and from which a confirmation of receipt is received.

Flood Damaged (NRS 487.740) means a motor vehicle which:

- (1) Has been submerged in water to a point that the level of the water is higher than the door sill of the vehicle and the water has entered the passenger, trunk or engine compartment of the vehicle and has come into contact with the electrical system of the vehicle; or
- (2) Has been acquired by an insurance company or retained by its owner or any other person as part of the total loss settlement resulting from water damage.

Inoperable Vehicle means vehicle which has been wrecked, destroyed or otherwise damaged to such an extent that the owner, leasing company, financial institution or the insurance company that insured the vehicle considers it uneconomical to repair the vehicle; and because of that wreckage, destruction or other damage, which is not repaired by or for the person who owned the vehicle at the time of the event resulting in the damage.

Junk Certificate (NRS 482.260) means a certificate issued by the Department that provides prima facie evidence of ownership and authorizes the disposal of a junk vehicle.

Junk Vehicle means a vehicle, including component parts which has been discarded or abandoned; has been ruined, wrecked, dismantled or rendered inoperative; is unfit for further use in accordance with the original purpose for which it was constructed; is not currently registered with the Department or has not been reclaimed by the registered owner or a person having a security interest in the vehicle within 15 days after notification pursuant to NRS 487.250; has value principally as scrap which does not exceed \$200.00.

Legal Owner means *legal owner* or lien holder who is a person (partnership, LLC or corporation) who holds a security interest in a vehicle and whose name appears on the certificate of title as *legal owner*.

Lien claimant (NAC 108.030) means any person who is entitled to a lien pursuant to [NRS 108.270](#) and who meets any of the following definitions:

1. An automobile wrecker as defined in [NAC 487.010](#);
2. A body shop as defined in [NRS 487.600](#);
3. A dealer as defined in [NRS 482.020](#);
4. A garage as defined in [NRS 487.540](#);
5. A salvage pool as defined in [NRS 487.400](#); or
6. An operator of a tow car as defined in [NAC 706.4024](#).

Lienholder (NRS 482.055) means a person who holds a security interest in a vehicle and whose name appears on the certificate of title as legal owner.

Lien Sale means the sale of a vehicle by auction pursuant to NRS 108.310 to satisfy a lien resulting from the storage, maintenance, keeping or repair of motor vehicles, including the operator of a salvage pool, as provided in NRS 108.270.

Manufacturer (NRS 482.060) means every person engaged in the business of manufacturing motor vehicles, trailers or semitrailers.

Mileage (49 C.F.R. 580.3) means actual distance that a vehicle has traveled.

Mini motor home (NRS 482.066) means a vehicular-type unit designed for temporary living quarters for travel, camping or recreational use which is a structure attached permanently on a self-propelled chassis or a portable unit designed to be affixed permanently to a truck chassis with cab, which is designed as a *mini motor home* by the manufacturer.

Motor home (NRS 482.071) means a structure attached permanently to a self-propelled motor vehicle chassis, designed as a temporary dwelling for travel, recreational or camping use and when assembled for the road, having a maximum body width of 102 inches.

Motor truck (NRS 482.073) means a motor vehicle designed, used or maintained primarily for the transportation of property.

Motor Vehicle (NRS 482.075) means every vehicle as defined in NRS 482.135, which is self-propelled.

Non-Repairable Vehicle (NRS 487.760) means a motor vehicle other than an abandoned vehicle, as defined in NRS 487.210, that:

- (1) Has value only as a source of parts or scrap metal;
- (2) Has been designated by its owner for dismantling as a source of parts or scrap metal;
- (3) Has been stripped of all body panels, doors, hatches, substantially all interior components and substantially all grill and light assemblies; or
- (4) Has been burned, destroyed or otherwise damaged to such an extent that it cannot be returned to a condition which is legal for operation on the highways of this state.

Non-Repairable Vehicle Certificate (RD-2NR) means a certificate printed on secure paper using the same standard format as used on a title.

Non-U.S. Vehicle means a motor vehicle that was manufactured outside of the United States and that was not provided with a U.S. warranty commonly referred to as a "grey-market vehicle."

Odometer (NRS 484.606) means an instrument for measuring and recording the total distance, which a motor vehicle travels while in operation. The term does not include any auxiliary *odometer* designed to be reset by the operator of the motor vehicle.

Odometer Brands means odometer brands are required for vehicles nine years old or newer. Vehicles greater than nine years old are classified "Exempt" from requirements of Title 49. *Odometer brands* may be one of the following:

- (1) The mileage stated is in excess of its mechanical limits.
- (2) The odometer reading is not the actual mileage. WARNING - ODOMETER DISCREPANCY
- (3) Exempt - Model year over 9 years old.

Odometer Disclosure Statement means a document or portion of a document that shows the vehicle's odometer reading and contains the seller's certification and the buyer's acknowledgment of the seller's certification that the odometer reading is correct.

Odometer Exempt means

- (1) A vehicle with a Gross Vehicle Weight of more than 16,000 pounds.
- (2) Vehicles not subject to registration, without an odometer or not self-propelled, such as a trailer or a vehicle that is not Street Legal.
- (3) Vehicles manufactured at least ten years before January 1 of the current calendar year, (example: vehicle transfers occurring during calendar year 2000, model year 1990 or older vehicles are exempt).
- (4) A vehicle sold directly by the manufacturer to any agency of the United States in conformity with contractual specifications.

Out-of-State Salvage Title or Certificate means a salvage title certificate issued by a state other than Nevada that was issued to indicate the vehicle was damaged, destroyed, wrecked or salvaged.

Owner (NRS 482.085) means a person who holds the legal title of a vehicle and whose name appears on the certificate of title, and any lienholder whose name appears on the certificate of title. If a vehicle is the subject of an agreement for the conditional sale or lease thereof with or without the right of purchase upon performance of the conditions stated in the agreement and with an immediate right of possession vested in the conditional vendee or lessee, or if a mortgagor of a vehicle is entitled to possession, then the conditional vendee or lessee or mortgagor shall be deemed the owner for the purpose of this chapter.

Property (NRS 132.285) means anything that may be the subject of ownership, and includes both real and personal property and any interest therein.

Rebuilt Vehicle (NRS 482.098) means a vehicle:

- (a) That is a salvage vehicle as that term is defined in NRS 487.770, excluding a non-repairable vehicle; or

(b) One or more major components of which have been replaced as set forth in this subsection. For the purposes of this subsection, the requisite major components of a vehicle which must be replaced for a vehicle to be considered rebuilt are the:

- (1) Cowl assembly;
- (2) Rear clip assembly;
- (3) Roof assembly;
- (4) Floor pan assembly;
- (5) Conventional frame coupled with one additional major component; or
- (6) Complete front inner structure for a unibody.

The term does not include a vehicle for which the only change is the installation of a truck cab assembly. For the purposes of this section, "replaced," means the substitution or change in whole of a new, used or after-market part of a vehicle.

Rebuilt Trailer means a trailer where one or more major components have been replaced. On a trailer, a major component is the frame, axle or wiring harness.

Reconstructed Trailer means any trailer that has been assembled or constructed largely by means of essential parts, new or used, derived from other trailers or vehicles or makes of trailers or vehicles of various names, models, or types which, if originally otherwise constructed, shall have been materially altered by the removal of essential parts or by the addition or substitution of essential parts, new or used, derived from other trailers or vehicles or makes of trailers or vehicles.

Reconstructed Vehicle (NRS 482.100) means any vehicle which shall have been assembled or constructed largely by means of essential parts, new or used, derived from other vehicles or makes of vehicles of various names, models or types, or which, if originally otherwise constructed, shall have been materially altered by the removal of essential parts or by the addition or substitution of essential parts, new or used, derived from other vehicles or makes of vehicles.

Registered Owner (NRS 482.102) means a natural person, firm, corporation or association whose name appears in the files of the Department as the person to whom the vehicle is registered.

Salvage Pool (NRS 487.400) means a business which obtains motor vehicles from: (1) insurers and self-insurers for sale on consignment or as an agent for the insurer or self-insurer if the vehicles are acquired by the insurer or self-insurer as the result of a settlement for insurance; or (2) Licensed vehicle dealers, rebuilders, lessors or wreckers for sale on consignment.

Salvage Title (NAC 487.010) means a title of ownership issued by the Department to an automobile wrecker authorizing the disposal of the vehicle identified on the *salvage title*.

Salvage Vehicle (NRS 487.770) means a motor vehicle that at any time has been declared a total loss vehicle, flood damaged vehicle, non-repairable vehicle or had "salvage" or a similar word or designation laced on any title issued for the vehicle.

Scrap means a vehicle whose appraised value does not exceed \$200.00.

Specially Constructed Trailer means any trailer that shall not have been originally constructed under a distinctive name, make, model, or type by a generally recognized manufacturer of trailers.

Specially Constructed Vehicle (NRS 482.120) means any vehicle, which shall not have been originally constructed under a distinctive name, make, model or type by a generally recognized manufacturer of vehicles.

Total Loss Vehicle (NRS 487.790) means a motor vehicle:

1. "Total loss vehicle" means a motor vehicle:
 - (a) Of a type which is subject to registration; and
 - (b) Which has been wrecked, destroyed or otherwise damaged to such an extent that the cost of repair is 65 percent or more of the fair market value of the vehicle immediately before it was wrecked, destroyed or otherwise damaged, except that, for the purposes of this paragraph, the cost of repair does not include the cost of:
 - (1) Painting any portion of the vehicle;
 - (2) Replacing electronic components in accordance with the specifications of the manufacturer; or
 - (3) Towing the vehicle.
2. The term does not include:
 - (a) A nonrepairable vehicle;
 - (b) A motor vehicle which is 10 model years old or older and which, to restore the vehicle to its condition before it was wrecked, destroyed or otherwise damaged and regardless of cost, requires the replacement of only:
 - (1) The hood;
 - (2) The trunk lid;
 - (3) A fender;
 - (4) Two or fewer of the following parts or assemblies, which may be bolted or unbolted:
 - (I) Doors;
 - (II) A grill assembly;
 - (III) A bumper assembly;
 - (IV) A headlight assembly; or
 - (V) A taillight assembly; or
 - (5) Any combination of subparagraph (1), (2), (3) or (4);
 - (c) A motor vehicle, regardless of the age of the vehicle, for which the cost to repair the vehicle is less than 65 percent of the fair market value of the vehicle immediately before the vehicle was wrecked, destroyed or otherwise damaged, except that, for the purposes of this paragraph, the cost of repair does not include the cost of:
 - (1) Painting any portion of the vehicle;
 - (2) Replacing electronic components in accordance with the specifications of the manufacturer; or
 - (3) Towing the vehicle; or

(d) A motor vehicle that was stolen and subsequently recovered, if the motor vehicle:

- (1) Has no structural damage; and
- (2) Is missing only tires, wheels, audio or video equipment, or some combination thereof.

3. For the purposes of this section, the model year of manufacture is calculated based on a year beginning on January 1 of the calendar year in which the damage occurs.

Towable Tools or equipment (NRS 484.202) means

1. All tools or equipment:
 - (a) Mounted on wheels;
 - (b) Whose body does not exceed 70 inches in width;
 - (c) Designed for towing by a motor vehicle; and
 - (d) Which is not designed or used primarily for the transportation of persons or property, but is only incidentally operated or moved upon a highway.
2. The term includes without limitation air compressors, concrete mixers, arc welders, tarpots, engine hoists, concrete pumps, plaster mixers, mortar mixers, grout pumps, portable conveyors, generators, log splitters, brush chippers, spray rigs, tree spades, scissor lifts, light towers, pumps, steam cleaners, sand blasters, welders, stump grinders, radial arm saws, sod cutters, aerators, pavement rollers, and scaffolding.

Tow Car Operator (NAC 706.4024) means the owner, manager, employee or agent of a company operating a tow car that holds a Certificate of Public Convenience and necessity issued by the Transportation Services Authority.

Trailer (NRS 482.125) means every vehicle without motive power designed to carry property or passengers wholly on its own structure and to be drawn by a motor vehicle.

Travel Trailer (NRS 482.127) means a portable structure mounted on wheels, constructed on a vehicular-type chassis primarily designed as temporary living quarters for recreational, camping or travel use and designed to be drawn by another vehicle and designated by the manufacturer as a travel trailer. A vehicle is not a travel trailer if, when equipped for highway use, it is more than 8 feet wide.

Vehicle (NRS 482.135) means every device in, upon or by which any person or property is or may be transported or drawn upon a public highway. The term does not include:

- Devices moved by human power or used exclusively upon stationary rails or tracks;
- Mobile homes or commercial coaches as defined in chapter 489 of NRS; or Electric personal assistive mobility devices.

Vehicle Identification Number (VIN) means the identification number or other distinguishing number or identification number or identification mark of a vehicle or part of a motor vehicle that was placed or stamped on that vehicle or part by the manufacturer pursuant to federal law or regulation, or as assigned by the Department of Motor Vehicles.

Vehicle Inspection Certificate (Form VP-15) means a form that must be completed following a vehicle examination by a Department inspector; a Nevada authorized agent or a law enforcement officer to verify a vehicle identification number (VIN).

“Verified mail” means any method of mailing offered by the United States Postal Service that provides evidence of mailing.

Index

A	
Abandoned Vehicle Liens	V-6
Abandoned Vehicle Lien Sale Transfer.....	V-6
Accessing Department of Motor Vehicle Information	VI-2
Acquiring Vehicles	I-7
Additional Licensing Privileges	I-7
Advertisement of Sale.....	V-19
Affidavit for Individual Record Information	VI-5
Affidavit of Publication.....	V-20
Application for Records Service.....	VI-4
Application for Salvage Title or Non-Repairable Vehicle Certificate.....	III-2
Appraisal Report for Abandoned Vehicles	V-14
Authority to Recover Claim not paid by Sale.....	V-6
Authorization for Vehicle Restoration.....	III-5
B	
Bill of Sale.....	III-7
C	
Certificate of Inspection / Affidavit Vehicle Construction	III-9
Certificate of Inspection for Rebuilt Vehicles.....	III-22
Collecting Sales Tax	V-21
D	
Definitions	I-5
Demand for Payment.....	V-17
Determining a Vehicle is Whole or Partial	I-8
E	
Erasure Affidavit.....	III-26
G	
Glossary.....	VII-2
Guidelines	I-2
I	
Importance of Accuracy	I-2
Incomplete or Incorrect Documents	I-4
Index.....	VII-11
Instruction for Completing VP-223	III-19
Instruction for Completing VP-64	III-11
Instruction for Completing VP-64M	III-15

J	Junk Certificate/Appraisal	II-20
L	Letter of Transmittal for Abandoned Junk Vehicles.....	V-12
	Licensing Requirements	I-6
	Lien Release / Satisfaction of Lien.....	III-28
	Lien Sale Affidavit	V-22
	Lien Sale Registration Certification	V-27
	Lien Sales	V-2
M	Motor Home Descriptions	I-8
N	Nevada Certificate of Title.....	II-2
	Nevada Salvage Title.....	II-10
	Non-Repairable Vehicle Certificate	II-16
	Notary Public	I-4
	Notice of Lien Sale.....	V-2
	Notification Abandoned Vehicle Liens.....	V-9
O	Out of State Salvage Certificates	II-15
P	Partial Vehicles	I-8
	Power of Attorney	III-30
	Private Property Abandoned Vehicle Release	V-7
R	Records Section Fee Schedule	VI-6
	Request for Extension of Time for Submitting Lien Sale Documents.....	V-29
	Requirements for the Tow Bill	V-10
	Retention of Salvage Vehicles	II-15
S	Sale by Public Action	V-21
	Submitting Lien Sale Documents	V-21
T	Title Fees	IV-2
	Towing Abandoned Vehicles	V-5
V	Validity may be Contested	V-6

Vehicle Identification Number (VIN) Information I-3
Vehicle Inspection Certificate..... III-33
Vehicle Registration, Title, and History InformationVI-3
Vehicles Abandoned at a Salvage Yard..... V-11
Vehicles Valued Over \$500 V-16
Vehicles Valued Under \$500 V-14
Verified Mailing V-18
VIN Schematic / Description I-3

W

Wrecker and Salvage Pool Licensing Information I-5